



**Made in USA**



## **EmArc**® Enhanced Metal Arc

EmArc® lighting technology is the culmination of a dedicated effort to bring together the inherent advantages of a number of gas discharge sources into a single light source. The technology equates to a critical blending of rare gas and metal additives to derive, in a single source, many of the key properties and benefits of stand alone Xenon, Metal Halide and Mercury lamps.

EmArc light sources are a series of highly efficient, Enhanced Metal Arc, DC gas discharge lamps designed for use in medical, scientific, industrial and entertainment settings. EmArc lamps are a progressive step ahead in lighting technology possessing features that offer advantages to an array of users for imaging, fiber optic and other important optical applications.

EmArc lamps have geometric designs which enable alignment in dichroic visible light or UV specific coated reflectors facilitating use in numerous applications like lighting for minimally invasive surgery, curing of light sensitive resins and adhesives and, dental whitening procedures. EmArc versatility enables its use in a number of entertainment applications including searchlights, followspots, special effects and automated fixtures.

EmArc lamps are comparable to Metal Halide sources in luminous efficacy but with 2 times to 5 times the life. A correlated color temperature like that of Xenon at 6000K, with very small arc gap sizes, but with 2 times the luminous efficacy of Xenon lamps.

EmArc technology differentiates itself as a new family of discharge lamps.

### **FEATURES & BENEFITS**

- Power Ranges from 150-600 Watts - Versatility / Power Tunability
- Custom Reflector Designs Available
- Small Arc Gap Sizes - Down to 1.2mm Highly Effective Optical Collection Capability
- Unique Hybrid Gas Discharge Technology - 2,000 Hours of Life; No Internal Pressure When Cold
- EmArc DC Technology - Enables Operation on Lower Cost DC Power Supplies Reducing OEM System Design Costs
- 6000K Correlated Color Temperature - Xenon-Like Light for Crisp, White Imaging
- Hot Reignition
- Up to 60 Lumens per Watt Efficacy - Two Times that of Xenon Sources
- Highly Durable, Rugged Elliptical and Parabolic Reflector Designs - Very High Light Path Efficiencies for Small Diameter Fiber Optic Bundle Applications
- Precise Filling Control, Electrode Design and Tight Manufacturing Tolerances with Tipless Arc Tube Construction Allows for Tightly Confined and Stable Plasma Discharge, Long Life with Minimal Color Temperature Drift Over Life, Better Optical Control, No Shadowing
- Far Better Color Control Over Life Than Conventional Metal Halide Lamps



The construction of EmArc arc tubes, electrodes and precise filling technique provide the environment for the tightly confined plasma arc discharge. EmArc light output over time exceeds that of typical DC Xenon and AC short-arc Metal Halide lamps.

**High luminance at tip of cathode with DC arc discharge**

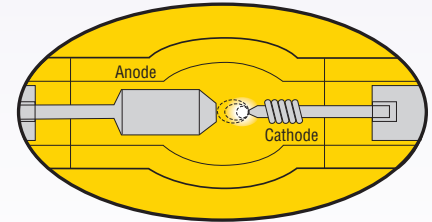

## APPLICATIONS

- Medical Fiber Optics for Endoscopy or Headlight Illumination
- Biotechnology / Micro-Array
- Industrial UV Curing
- Machine Vision
- Cosmetic Dentistry
- Projection / Entertainment
- Microscopy
- Boroscopy
- Phototherapy

Watts (W)	Ordering Code	Lamp Description	Lamp Voltage (V)	Lamp Current (A)	Arc Gap (mm)	Color** (K)	Luminous Flux (lm) nom	Average* Rated Life (h)	Fig No.
160 - 200	—	SMH-200/D1	43	4.65	1.2	6000	10000	2000	1
350	5002486	SMH-350/D2	48	7.30	1.8	6000	21000	2000	2
600	—	SMH-600/D1	68	8.80	3.0	5700	44000	1000	3
600	5001335	SMH-600/SC1	68	8.80	3.0	5700	45000	1000	—
850	5001634	SMH-850/SB1	90	9.40	3.5	6000	70000	1000	—
850	5001470	SMH-850/SC1	90	9.40	3.5	60000	70000	1000	—
850	5001477	SMH-850/D2	90	9.40	3.5	6000	70000	1000	4

\* Based on 50% spherical lumen depreciation at a duty cycle of 2 hours 45 minutes ON and 15 minutes OFF.

\*\*As measured in a sphere. All values  $\pm$  500K from nominal.

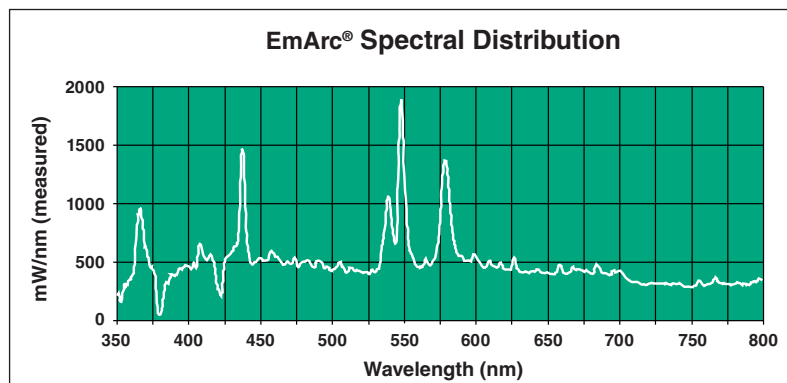

**⚠ CALIFORNIA PROPOSITION 65 WARNING:** These products can expose you to Mercury known to the state of California to cause birth defects or other reproductive harm. For more information, please go to: [www.p65warnings.ca.gov](http://www.p65warnings.ca.gov).

contains mercury  
contient du mercure



Manage in Accord with Disposal Laws  
[www.lamprecycle.org](http://www.lamprecycle.org) 1-800-895-8842

# SMR SPECIFICATIONS

## REFLECTORIZED VERSIONS 70mm Reflector

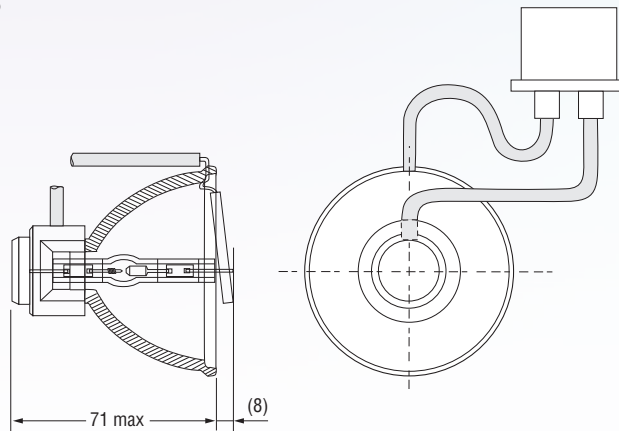

Lamp aligned for maximum throughput thru 6mm aperture at 52mm distance from reflector rim.

Watts (W)	Ordering Code	Lamp Description	Lamp Voltage (V)	Lamp Current (A)	Arc Gap (mm)	Color***	Luminous* Flux (lm) nom	Average** Rated Life (h)
160 - 200	5001399	SMR-200/D1	43	4.65	1.2	6500	5100/6mm Aperture	2000
160 - 200	5001523	SMR-201/D1	47	4.25	1.6	6500	5500/8mm Aperture	2500
160 - 200	5001466	SMR-202/D1	56	3.50	2.0	6900	5900/10mm Aperture	4000

\* Based on measurement through aperture into a sphere.

All dimensions shown in millimeters unless otherwise noted.

\*\* Based on 50% spherical lumen depreciation at a duty cycle of 2 hours 45 minutes ON and 15 minutes OFF.

\*\*\* As measured in a sphere. All values  $\pm$  500K from nominal.

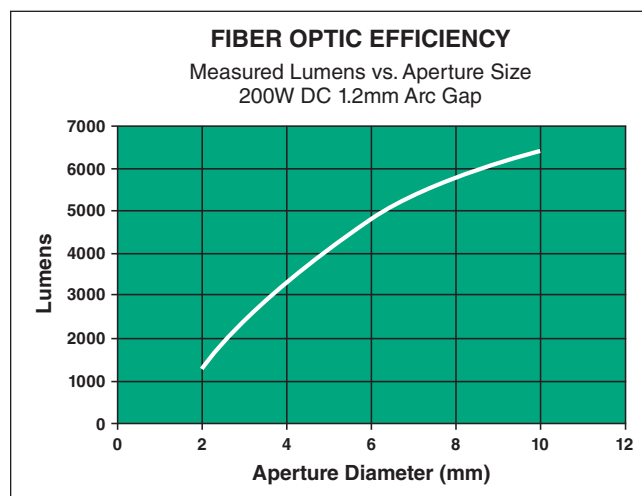

**▲ CALIFORNIA PROPOSITION 65 WARNING:** These products can expose you to Mercury known to the state of California to cause birth defects or other reproductive harm. For more information, please go to: [www.p65warnings.ca.gov](http://www.p65warnings.ca.gov).

 contains mercury  
contient du mercure



Manage in Accord with Disposal Laws  
[www.lamprecycle.org](http://www.lamprecycle.org) 1-800-895-8842

# SMR-100/UV1 SPECIFICATIONS

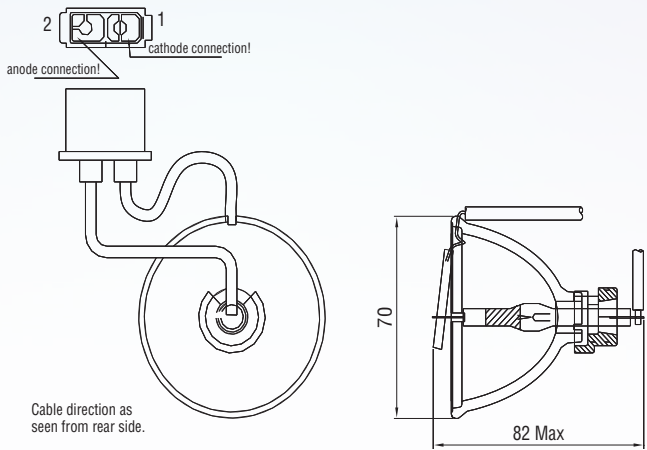

Focal point of reflector is at 52mm from reflector rim.

Watts (W)	Ordering Code	Lamp Description	Lamp Voltage (V)	Lamp Current (A)	Arc Gap (mm)	Radiant* Output (0 hrs)	Minimum Voltage After Start Up	Typical Warm Up Time	Average** Rated Life (h)
100	5001478	SMR-100/UV1	20 (±4)	5.00	0.6	3.0W min.	10 - 15V DC	90 sec. nom.	750

\* As measured in the range of 320-400nm through a 6mm aperture at a working distance of 52mm from reflector rim. Actual values dependent upon optical setup.

All dimensions shown in millimeters unless otherwise noted.

\*\*Life defined as 50% drops of initial output. Strongly dependent upon operating conditions, environment, and type of power supply used.

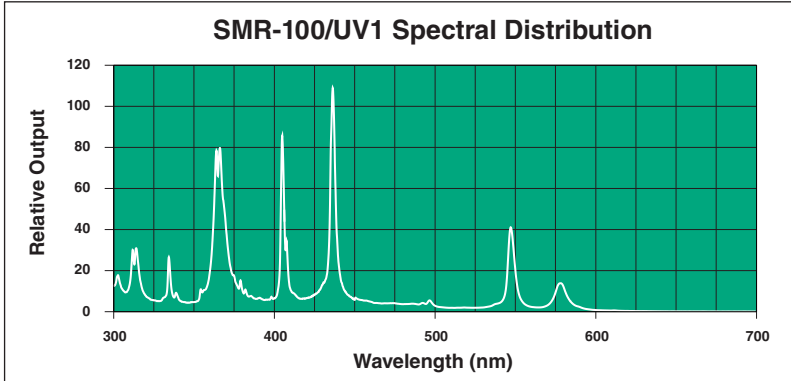

**⚠ CALIFORNIA PROPOSITION 65 WARNING:** These products can expose you to Mercury known to the state of California to cause birth defects or other reproductive harm. For more information, please go to: [www.p65warnings.ca.gov](http://www.p65warnings.ca.gov).

contains mercury  
 contient du mercure  
 Manage in Accord with Disposal Laws  
[www.lamprecycle.org](http://www.lamprecycle.org) 1-800-895-8842

# SMR-201/UV1 SPECIFICATIONS

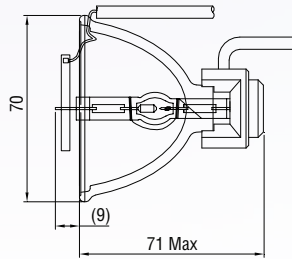
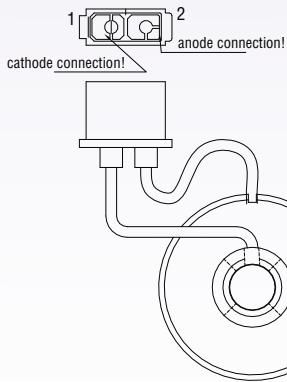

Lamp aligned for max throughput thru 6mm aperture at 52mm dist from reflector rim.

Watts (W)	Ordering Code	Lamp Description	Lamp Voltage (V)	Lamp Current (A)	Arc Gap (mm)	Radiant* Output (0 hrs)	Minimum Voltage After Start Up	Typical Warm Up Time	Average** Rated Life (h)
200	5002183	SMR-201/UV1 (Reflectorized Version)	40 (±5)	5.00	1.2	5.0W min.	10 - 15V DC	90 sec. nom.	1500

\* As measured in the range of 320-400nm through a 6mm aperture at a working distance of 52mm from reflector rim.

All dimensions shown in millimeters unless otherwise noted.

\*\*Life defined as time until output drops to 50% of initial value at 0 hours. (Strongly dependent upon operating conditions and environment).

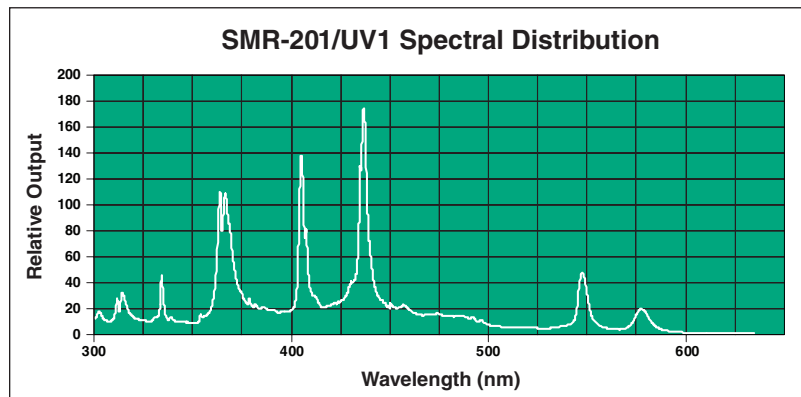

**⚠ CALIFORNIA PROPOSITION 65 WARNING:** These products can expose you to Mercury known to the state of California to cause birth defects or other reproductive harm. For more information, please go to: [www.p65warnings.ca.gov](http://www.p65warnings.ca.gov).

 contains mercury  
contient du mercure



Manage in Accord with Disposal Laws  
[www.lamprecycle.org](http://www.lamprecycle.org) 1-800-895-8842

## SmartArc™ ELDC 2.31 - Item #5002001

Power Supply For EmArc® Lamps

Ushio's SMARTARC™ electronic power supply with digital power management and microprocessor controls is a compact and “intelligent” solution for operating DC operated arc discharge lamps.

All values are valid at 25° ±5°C, unless otherwise noted.

### INPUT DATA

Nominal Operation	Nominal	Tolerance
Input Voltage AC (V)	100 – 240	90 – 264
Input Voltage DC (V)	100 – 300	90 – 340
System Wattage (W)	200	100 – 200*
Input Current (A)	—	1 – 3
Line Frequency (Hz)	50/60	47 – 63
Power Factor (1)	1.0	>0.93

\*Tolerance for System wattage dependent on preset.

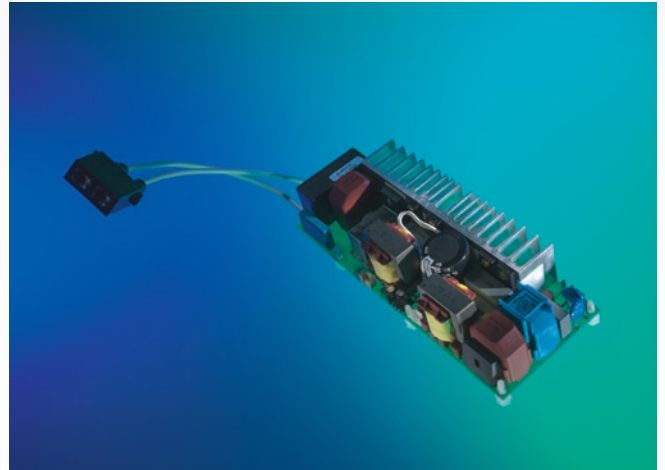

### LAMP OUTPUT DATA

Ignition	Nominal	Tolerance	Remarks
Ignition Voltage (kV peak)	±14	±12 – ±16	Load Capacity <20pF
Ignition Time (sec.)	1	0.9 – 1.1	
Automatic Restart Counter (1)	5	—	Attempts
Nominal Operation	Nominal	Tolerance	
Lamp Voltage (V)	60	36 – 95	
Lamp Wattage (W)	100 – 200*	—	
Lamp Current (A)	—	I Max = 5.7	
Cut-Off Voltage, End-Life (V)	98	99 – 101	
Open Circuit Voltage (V)	240	230 – 260	

\*Presettable in 6 steps. Continuous variable from preset to 200W by optocoupler.

## ACCESSORIES (SOLD SEPARATELY)

### SmartArc™ UBX 76 - Item #5001569

For EmArc® & DC Gas Discharge Lamps

Ushio's SMARTARC™ electronic power supply with digital power management and microprocessor controls is a compact and “intelligent” solution for operating DC operated arc discharge lamps.

All values are valid at 25° ±5°C, unless otherwise noted.

#### INPUT DATA

Nominal Operation	Nominal	Tolerance
Input Voltage AC (V)	100 – 240	90 – 264
Input Voltage DC (V)	100 – 300	900 – 340
System Wattage (W)	—	60 – 120*
Input Current (A)	—	0.6 – 1.4*
Line Frequency (Hz)	50/60 and DC	47 – 63
Power Factor (1)	—	0.93 – 1.0

\*Depends on lamp selected. Presettable.

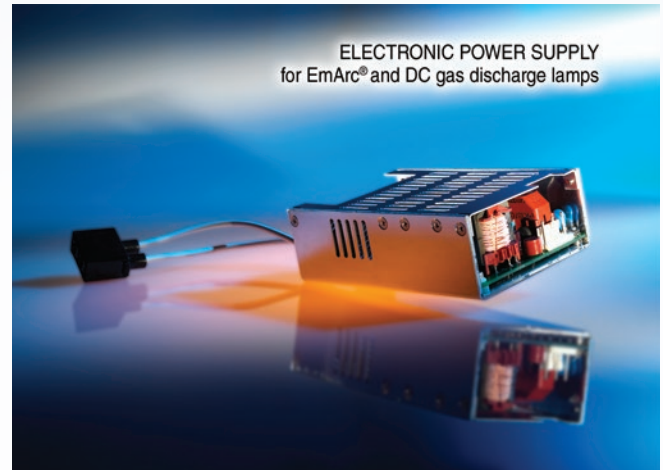

#### LAMP OUTPUT DATA

Ignition	Nominal	Tolerance	Remarks
Ignition Voltage (kV peak)	±14	±12 – ±16	Load Capacity <20pF
Ignition Time (sec.)	1	0.9 – 1.1	
Automatic Restart Counter (1)	5	—	Attempts
Nominal Operation	Nominal	Tolerance	
Lamp Voltage (V)	40 – 80	±5%*	
Lamp Wattage (W)	50, 75, 100*	selectable 50, 75, 100W	
Cut-Off Voltage, End-Life (A)	100	±2	
HF-Ripple of Output Power (ΔP La,rip/PLa)	%<1 p-p		
Ripple 50Hz - 60Hz	%<2 p-p		
Output Power Shift vs. Input Voltage (ΔP La/ΔLI)		<0.005 with nominal values	

\*Depends on lamp selected. Presettable.

# USHIO