

# PHILIPS LIGHTOLIER

## Downlighting

### SlimSurface LED

5" and 7" round aperture  
surface mount downlight



Project: \_\_\_\_\_  
 Location: \_\_\_\_\_  
 Cat.No: \_\_\_\_\_  
 Type: \_\_\_\_\_  
 Lamps: \_\_\_\_\_ Qty: \_\_\_\_\_  
 Notes: \_\_\_\_\_

SlimSurface LED is a 5/8" thick surface mounted luminaire with the appearance of a recessed downlight. Easy to install into most standard j-boxes, the SlimSurface LED round apertures are available as a 5" 650lm & 7" 1000lm fixture.

### Ordering guide

example: S5R830K7AL

Family	CRI	CCT	Lumens	Finish	Dimming
<input type="checkbox"/>	<input type="checkbox"/>	<input type="checkbox"/>	<input type="checkbox"/>	<input type="checkbox"/>	<input type="checkbox"/>
<b>S5R</b> SlimSurface 5" Round	<b>8</b> 80 <b>9</b> 90 <sup>1</sup>	<b>27K</b> 2700K <b>30K</b> 3000K <b>35K</b> 3500K <b>40K</b> 4000K	<b>7</b> 650lm	<b>blank</b> White <b>AL</b> Aluminum <b>BK</b> Black  <b>W</b> White <b>AL</b> Aluminum <b>BK</b> Black	<b>blank</b> ELV / Triac (120V)  <b>Z10U</b> 0-10V (120V-277V)
<b>S7R</b> SlimSurface 7" Round	<b>8</b> 80 <b>9</b> 90 <sup>1</sup>	<b>27K</b> 2700K <b>30K</b> 3000K <b>35K</b> 3500K <b>40K</b> 4000K	<b>10</b> 1000lm	<b>blank</b> White <b>AL</b> Aluminum <b>BK</b> Black  <b>W</b> White <b>AL</b> Aluminum <b>BK</b> Black	<b>blank</b> ELV / Triac (120V)  <b>Z10U</b> 0-10V (120V-277V)

1. Configurations using 90 CRI are only available with 2700K CCT.



White



Black



Aluminum

### Features

- Flange:** One piece plastic flange. Injection molded white, applied aluminum or black.
- Lens:** High transmittance lens allowing for smooth, comfortable light pattern.
- Power supply:** Integral class 2 driver. Factory wired electronic LED driver (see Electrical section for specifications)
- LED Strip:** Utilizes Philips LEDs.
- Lifetime:** Expected lifetime 50,000 hours and backed by a 5-year warranty (see Philips.com/warranties for details).
- Compliance:** Non-conductive fixture for shower light application.

### Electrical

**Electronic power supply:** RoHS compliant. Class 2 power unit. Unit tolerates sustained open circuit and short circuit output conditions without damage.

**Dimming:** Intended for ELV/Triac (120V) or 0-10V dimming (120V-277V) based on the configuration. Min 90°C supply conductors.

### Labels

cULus listed for damp locations (wall mount applications and wet location - covered ceilings). ENERGY STAR® certified.

Electrical specifications	Dimming	Input volts	Input frequency	Input current	Input Power	THD Factor	Power Factor	Minimum Operating Temp.
Slim 5" 650lm	Triac	120V	50/60Hz	0.08A	9.5W	<15%	>0.9	-20°C
	0-10V	120V	50/60Hz	0.09A	10.1W	<20%	>0.9	-20°C
		277V	50/60Hz	0.04A	10.2W	<20%	>0.9	-20°C
Slim 7" 1000lm	Triac	120V	50/60Hz	0.13A	14.2W	<15%	>0.9	-20°C
	0-10V	120V	50/60Hz	0.12A	14.4W	<20%	>0.9	-20°C
		277V	50/60Hz	0.06A	14.7W	<20%	>0.9	-20°C

For more details, please see LED-Dim spec sheet.



# S5R & S7R SlimSurface LED

5" and 7" round aperture surface mount downlight

## Compatibility

Installs into standard J-box applications:



3 1/2" round (plastic)



4" square (plastic)  
Not compatible with S5R



4" octagonal (metal)



4" square (metal)  
Not compatible with S5R



Fire rated J-box  
Fire rated classification is per the ceiling and junction box ratings.

Note: A 2 1/8" deep octagon junction box is recommended for through circuit wiring applications.

## Dimensions

### SlimSurface LED 5" downlight

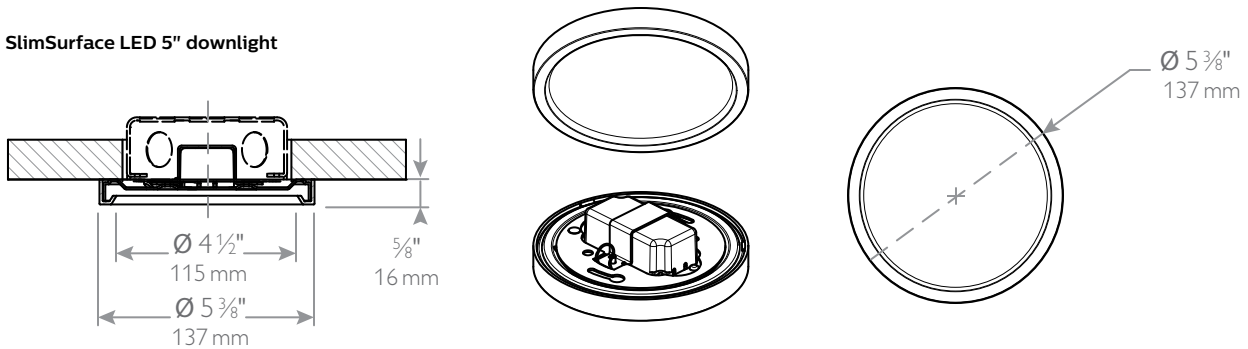

### SlimSurface LED 7" downlight

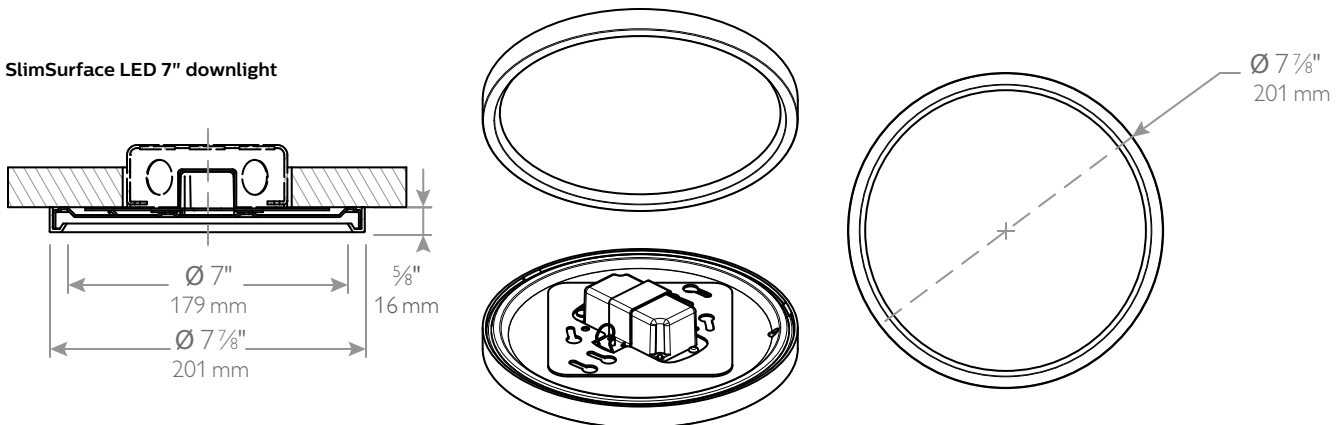

# S5R & S7R SlimSurface LED

5" and 7" round aperture surface mount downlight

## S5R927K7 • 10 W LED, 90CRI, 2700K

Candela Curves

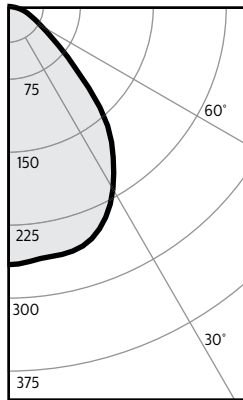

Angle	Mean CP	Lumens
0	266	
5	263	25
10	261	
15	260	736
20	254	
25	239	110
30	217	
35	190	118
40	160	
45	118	91
50	81	
55	55	51
60	40	
65	30	31
70	23	
75	18	18
80	11	
85	4	5
90	0	

Single unit data

Height to Lighted Plane	Initial center beam foot-candles	Beam dia. (ft)*
5'	11	6.0'
6'	7	7.2'
7'	5	8.4'
8'	4	9.6'
9'	3	10.8'

\* Beam diameter is where foot-candles drop to 50% of maximum.

Multiple unit data - RCR 2

Spacing on center	Initial center beam foot-candles	Watts per sq.ft.
5'	21.8	0.40
6'	14.2	0.26
7'	10.2	0.19
8'	8.5	0.16
9'	6.8	0.13

Coefficients of utilization

Ceiling	80%					70%		50%		30%		0%
	70	50	30	10	50	10	50	10	50	10	0	
Wall	70	50	30	10	50	10	50	10	50	10	0	
RCR	Zonal cavity method - Effective floor reflectance = 20%											
Room Cavity Ratio	0	119	119	119	119	116	116	111	111	106	106	100
	1	111	107	103	100	105	98	100	95	97	92	88
	2	102	96	90	85	94	84	90	82	87	80	77
	3	95	86	79	73	84	73	82	72	79	70	67
	4	88	78	70	64	76	64	74	63	72	62	60
	5	82	71	63	57	70	57	68	56	66	56	53
	6	76	64	57	51	64	51	62	50	60	50	48
	7	71	59	51	46	58	46	57	45	56	45	43
	8	67	54	47	42	54	41	53	41	51	41	39
	9	63	50	43	38	50	38	49	38	48	37	36
	10	59	47	40	35	46	35	45	34	44	34	33

Zonal lumens & percentages

Zone	Lumens	%Luminaire
0-30	208	39.8%
0-40	326	62.5%
0-60	469	89.7%
0-90	522	100.0%

CRI and CCT adjustment factors

90 CRI 2700K = 84%
80 CRI 2700K = 100%
80 CRI 3000K = 100%
80 CRI 3500K = 105%
80 CRI 4000K = 109%

Report: 1053GFR

Output lumens:	523lms	Efficacy:	57.4lm/w
Spacing Criterion:	1.2	CCT <sup>3</sup> :	2700K
Beam Angle:	87°	CRI:	90min
Input Watts <sup>2</sup> :	9.1W		

38'x38'x10' Room, Workplane 2.5' above floor, 80/50/20% Reflectances

## S7R927K7 • 14 W LED, 90CRI, 2700K

Candela Curves

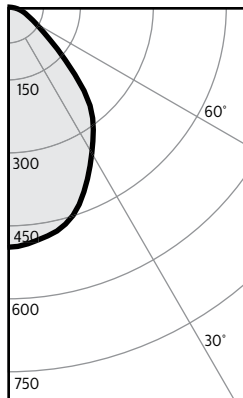

Angle	Mean CP	Lumens
0	496	
5	490	46
10	479	
15	464	130
20	433	
25	391	180
30	348	
35	309	193
40	265	
45	197	152
50	135	
55	92	85
60	68	
65	51	52
70	40	
75	30	32
80	21	
85	9	10
90	0	

Single unit data

Height to Lighted Plane	Initial center beam foot-candles	Beam dia. (ft)*
5'	20	5.5'
6'	14	6.6'
7'	10	7.7'
8'	8	8.8'
9'	6	9.9'

\* Beam diameter is where foot-candles drop to 50% of maximum.

Multiple unit data - RCR 2

Spacing on center	Initial center beam foot-candles	Watts per sq.ft.
5'	21.8	2.89
6'	14.2	1.90
7'	10.2	1.35
8'	8.5	1.13
9'	6.8	0.90

Coefficients of utilization

Ceiling	80%					70%		50%		30%		0%
	70	50	30	10	50	10	50	10	50	10	0	
Wall	70	50	30	10	50	10	50	10	50	10	0	
RCR	Zonal cavity method - Effective floor reflectance = 20%											
Room Cavity Ratio	0	119	119	119	119	116	116	111	111	106	106	100
	1	111	107	103	100	104	98	100	95	96	92	88
	2	102	96	90	85	94	84	90	82	87	80	77
	3	95	86	79	74	85	73	82	72	79	71	67
	4	88	78	70	65	77	64	74	63	72	62	60
	5	82	71	63	57	70	57	68	56	66	56	53
	6	76	65	57	51	64	51	62	51	61	50	48
	7	71	59	52	46	59	46	57	46	56	45	43
	8	67	55	47	42	54	42	53	42	52	41	39
	9	63	51	43	38	50	38	49	38	48	38	36
	10	59	47	40	35	47	35	46	35	45	35	33

Zonal lumens & percentages

Zone	Lumens	%Luminaire
0-30	356	40.5%
0-40	549	62.4%
0-60	786	89.3%
0-90	880	100.0%

CRI and CCT adjustment factors

90 CRI 2700K = 84%
80 CRI 2700K = 100%
80 CRI 3000K = 100%
80 CRI 3500K = 105%
80 CRI 4000K = 109%

Report: 962GFR

Output lumens:	880lms	Efficacy:	65.2lm/w
Spacing Criterion:	1.1	CCT <sup>3</sup> :	2700K
Beam Angle:	83°	CRI:	90min
Input Watts <sup>2</sup> :	13.5W		

38'x38'x10' Room, Workplane 2.5' above floor, 80/50/20% Reflectances

1. Tested using absolute photometry as specified in LM79: IESNA Approved Method for the Electrical and Photometric Measurements of Solid-State Lighting Products.  
 2. Wattage: controlled to within 5%  
 3. Correlated Color Temperature: within specs as defined in ANSI\_NEMA\_ANSI C78.377-2008: Specifications for the Chromaticity of Solid State Lighting Products.

# S5R & S7R SlimSurface LED

5" and 7" round aperture surface mount downlight

## S5R827K7 • 10 W LED, 80CRI, 2700K

Candela Curves

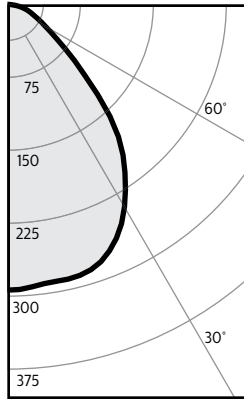

Angle	Mean CP	Lumens
0	294	28
5	291	
10	289	
15	288	81
20	281	
25	265	121
30	241	
35	211	131
40	178	
45	131	102
50	91	
55	62	57
60	45	
65	34	34
70	26	
75	20	21
80	13	
85	4	5
90	0	

Single unit data

Height to Lighted Plane	Initial center beam foot-candles	Beam dia. (ft)*
5'	12	6.0'
6'	8	7.2'
7'	6	8.4'
8'	5	9.6'
9'	4	10.8'

\* Beam diameter is where foot-candles drop to 50% of maximum.

Multiple unit data - RCR 2

Spacing on center	Initial center beam foot-candles	Watts per sq.ft.
5'	24.2	2.77
6'	15.8	1.82
7'	11.3	1.30
8'	9.5	1.08
9'	7.5	0.87

38'x38'x10' Room, Workplane 2.5' above floor, 80/50/20% Reflectances

Coefficients of utilization

Ceiling	80%				70%		50%		30%		0%	
	70	50	30	10	50	10	50	10	50	10	0	
Wall	70	50	30	10	50	10	50	10	50	10	0	
RCR	Zonal cavity method - Effective floor reflectance = 20%											
Room Cavity Ratio	0	119	119	119	119	116	116	111	111	106	106	100
	1	111	107	103	100	105	105	100	95	97	92	88
	2	102	96	90	85	94	94	90	82	87	80	77
	3	95	86	79	73	84	84	82	72	79	70	67
	4	88	78	70	64	76	76	74	63	72	62	60
	5	82	71	63	57	70	70	68	56	66	56	53
	6	76	64	57	51	64	64	62	50	60	50	48
	7	71	59	51	46	58	58	57	45	56	45	43
	8	67	54	47	42	54	54	53	41	51	41	39
	9	63	50	43	38	50	50	49	38	48	37	36
	10	59	47	40	35	46	46	45	34	44	34	33

Zonal lumens & percentages

Zone	Lumens	%Luminaire
0-30	231	39.7%
0-40	362	62.3%
0-60	521	89.6%
0-90	581	100.0%

CRI and CCT adjustment factors

90 CRI 2700K = 84%
80 CRI 2700K = 100%
80 CRI 3000K = 100%
80 CRI 3500K = 105%
80 CRI 4000K = 109%

Report: 1054GFR

Output lumens:	581lms	Efficacy:	62.5lm/w
Spacing Criterion:	1.2	CCT <sup>3</sup> :	2700K
Beam Angle:	87°	CRI:	80min
Input Watts <sup>2</sup> :	9.3W		

## S7R827K7 • 14 W LED, 80CRI, 2700K

Candela Curves

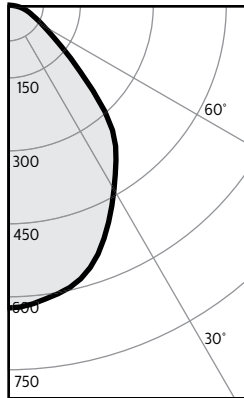

Angle	Mean CP	Lumens
0	625	59
5	618	
10	604	
15	584	164
20	546	
25	494	227
30	440	
35	390	244
40	337	
45	250	193
50	170	
55	117	108
60	85	
65	65	65
70	51	
75	39	41
80	27	
85	12	13
90	0	

Single unit data

Height to Lighted Plane	Initial center beam foot-candles	Beam dia. (ft)*
5'	25	5.5'
6'	17	6.6'
7'	13	7.7'
8'	10	8.8'
9'	8	9.9'

\* Beam diameter is where foot-candles drop to 50% of maximum.

Multiple unit data - RCR 2

Spacing on center	Initial center beam foot-candles	Watts per sq.ft.
5'	24.2	3.68
6'	15.8	2.42
7'	11.3	1.73
8'	9.5	1.44
9'	7.5	1.15

38'x38'x10' Room, Workplane 2.5' above floor, 80/50/20% Reflectances

Coefficients of utilization

Ceiling	80%				70%		50%		30%		0%	
	70	50	30	10	50	10	50	10	50	10	0	
Wall	70	50	30	10	50	10	50	10	50	10	0	
RCR	Zonal cavity method - Effective floor reflectance = 20%											
Room Cavity Ratio	0	119	119	119	119	116	116	111	111	106	106	100
	1	111	107	103	100	104	98	100	95	96	92	88
	2	102	96	90	85	94	84	90	82	87	80	77
	3	95	86	79	74	85	73	82	72	79	71	67
	4	88	78	70	65	77	64	74	63	72	62	60
	5	82	71	63	57	70	57	68	56	66	56	53
	6	76	65	57	51	64	51	62	51	61	50	48
	7	71	59	52	46	59	46	57	46	56	45	43
	8	67	55	47	42	54	42	53	42	52	41	39
	9	63	51	43	38	50	38	49	38	48	38	36
	10	59	47	40	35	47	35	46	35	45	35	33

Zonal lumens & percentages

Zone	Lumens	%Luminaire
0-30	449	40.4%
0-40	693	62.3%
0-60	994	89.3%
0-90	1113	100.0%

CRI and CCT adjustment factors

90 CRI 2700K = 84%
80 CRI 2700K = 100%
80 CRI 3000K = 100%
80 CRI 3500K = 105%
80 CRI 4000K = 109%

Report: 964GFR

Output lumens:	1113lms	Efficacy:	83.1lm/w
Spacing Criterion:	1.1	CCT <sup>3</sup> :	2700K
Beam Angle:	83°	CRI:	80min
Input Watts <sup>2</sup> :	13.4W		

1. Tested using absolute photometry as specified in LM79: IESNA Approved Method for the Electrical and Photometric Measurements of Solid-State Lighting Products.  
 2. Wattage: controlled to within 5%  
 3. Correlated Color Temperature: within specs as defined in ANSI\_NEMA\_ANSI C78.377-2008: Specifications for the Chromaticity of Solid State Lighting Products.

# S5R & S7R SlimSurface LED

5" and 7" round aperture surface mount downlight

## S5R830K7 • 10 W LED, 80 CRI, 3000 K

Candela Curves

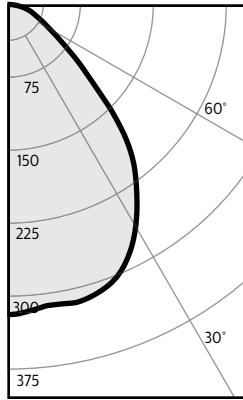

Angle	Mean CP	Lumens
0	319	30
5	315	
10	313	
15	313	88
20	306	
25	290	131
30	264	
35	231	142
40	197	
45	146	109
50	100	
55	69	62
60	50	
65	38	37
70	29	
75	22	22
80	15	
85	6	6
90	0	

Single unit data

Height to Lighted Plane	Initial center beam foot-candles	Beam dia. (ft)*
5'	13	6.0'
6'	9	7.2'
7'	7	8.4'
8'	5	9.6'
9'	4	10.8'

\* Beam diameter is where foot-candles drop to 50% of maximum.

Multiple unit data - RCR 2

Spacing on center	Initial center beam foot-candles	Watts per sq.ft.
5'	26.2	3.06
6'	17.1	2.01
7'	12.2	1.43
8'	10.2	1.19
9'	8.1	0.96

38'x38'x10' Room, Workplane 2.5' above floor, 80/50/20% Reflectances

Coefficients of utilization

Ceiling	80%				70%		50%		30%		0%
	70	50	30	10	50	10	50	10	50	10	0
Wall	70	50	30	10	50	10	50	10	50	10	0

RCR Zonal cavity method - Effective floor reflectance = 20%

Room Cavity Ratio	80%				70%		50%		30%		0%
	70	50	30	10	50	10	50	10	50	10	0
0	119	119	119	119	116	116	111	111	106	106	100
1	111	107	103	100	105	98	100	95	97	92	88
2	102	96	90	85	94	84	90	82	87	80	77
3	95	86	79	73	84	73	82	72	79	70	67
4	88	78	70	64	76	64	74	63	72	62	60
5	82	71	63	57	70	57	68	56	66	56	53
6	76	64	57	51	64	51	62	50	60	50	48
7	71	59	51	46	58	46	57	45	56	45	43
8	67	54	47	42	54	41	53	41	51	41	39
9	63	50	43	38	50	38	49	38	48	37	36
10	59	47	40	35	46	35	45	34	44	34	33

Zonal lumens & percentages

Zone	Lumens	%Luminaire
0-30	249	39.7%
0-40	391	62.3%
0-60	562	89.6%
0-90	628	100.0%

CRI and CCT adjustment factors

90 CRI 2700K = 84%
80 CRI 2700K = 100%
80 CRI 3000K = 100%
80 CRI 3500K = 105%
80 CRI 4000K = 109%

Report: 1055GFR

Output lumens:	628lms	Efficacy:	69.0lm/w
Spacing Criterion:	1.2	CCT <sup>3</sup> :	3000K
Beam Angle:	87°	CRI:	80min
Input Watts <sup>2</sup> :	9.1W		

## S7R830K7 • 14 W LED, 80 CRI, 3000 K

Candela Curves

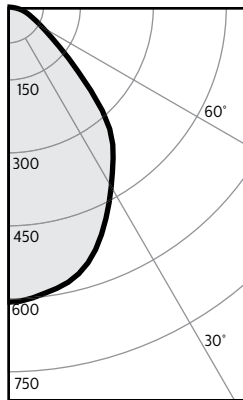

Angle	Mean CP	Lumens
0	607	57
5	601	
10	588	
15	568	159
20	531	
25	480	221
30	427	
35	379	237
40	328	
45	243	187
50	165	
55	113	105
60	83	
65	63	63
70	49	
75	37	39
80	26	
85	12	13
90	0	

Single unit data

Height to Lighted Plane	Initial center beam foot-candles	Beam dia. (ft)*
5'	24	5.5'
6'	17	6.6'
7'	12	7.7'
8'	9	8.8'
9'	7	9.9'

\* Beam diameter is where foot-candles drop to 50% of maximum.

Multiple unit data - RCR 2

Spacing on center	Initial center beam foot-candles	Watts per sq.ft.
5'	26.2	3.55
6'	17.1	2.33
7'	12.2	1.66
8'	10.2	1.39
9'	8.1	1.11

38'x38'x10' Room, Workplane 2.5' above floor, 80/50/20% Reflectances

Coefficients of utilization

Ceiling	80%				70%		50%		30%		0%
	70	50	30	10	50	10	50	10	50	10	0
Wall	70	50	30	10	50	10	50	10	50	10	0

RCR Zonal cavity method - Effective floor reflectance = 20%

Room Cavity Ratio	80%				70%		50%		30%		0%
	70	50	30	10	50	10	50	10	50	10	0
0	119	119	119	119	116	116	111	111	106	106	100
1	111	107	103	100	104	98	100	95	96	92	88
2	102	96	90	85	94	84	90	82	87	80	77
3	95	86	79	74	85	73	82	72	79	71	67
4	88	78	70	65	77	64	74	63	72	62	60
5	82	71	63	57	70	57	68	56	66	56	53
6	76	65	57	51	64	51	62	51	61	50	48
7	71	59	52	46	59	46	57	46	56	45	43
8	67	55	47	42	54	42	53	42	52	41	39
9	63	51	43	38	50	38	49	38	48	38	36
10	59	47	40	35	47	35	46	35	45	35	33

Zonal lumens & percentages

Zone	Lumens	%Luminaire
0-30	437	40.4%
0-40	674	62.3%
0-60	966	89.4%
0-90	1081	100.0%

CRI and CCT adjustment factors

90 CRI 2700K = 84%
80 CRI 2700K = 100%
80 CRI 3000K = 100%
80 CRI 3500K = 105%
80 CRI 4000K = 109%

Report: 961GFR

Output lumens:	1081lms	Efficacy:	80.0lm/w
Spacing Criterion:	1.1	CCT <sup>3</sup> :	3000K
Beam Angle:	83°	CRI:	80min
Input Watts <sup>2</sup> :	13.5W		

1. Tested using absolute photometry as specified in LM79: IESNA Approved Method for the Electrical and Photometric Measurements of Solid-State Lighting Products.  
 2. Wattage: controlled to within 5%  
 3. Correlated Color Temperature: within specs as defined in ANSI\_NEMA\_ANSI C78.377-2008: Specifications for the Chromaticity of Solid State Lighting Products.



# S5R & S7R SlimSurface LED

5" and 7" round aperture surface mount downlight

## S5R840K7 • 10 W LED, 80CRI, 4000 K

Candela Curves

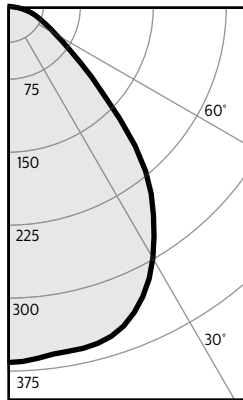

Angle	Mean CP	Lumens
0	366	
5	363	35
10	360	
15	359	101
20	350	
25	329	151
30	299	
35	262	163
40	221	
45	163	126
50	113	
55	79	72
60	57	
65	44	44
70	34	
75	25	27
80	16	
85	6	7
90	0	

Single unit data

Height to Lighted Plane	Initial center beam foot-candles	Beam dia. (ft)*
5'	15	6.0'
6'	10	7.2'
7'	7	8.4'
8'	6	9.6'
9'	5	10.8'

\* Beam diameter is where foot-candles drop to 50% of maximum.

Multiple unit data - RCR 2

Spacing on center	Initial center beam foot-candles	Watts per sq.ft.
5'	30.3	3.54
6'	19.8	2.32
7'	14.1	1.66
8'	11.8	1.38
9'	9.4	1.10

Coefficients of utilization

Ceiling	80%					70%		50%		30%		0%
	70	50	30	10	50	10	50	10	50	10	0	
Wall	70	50	30	10	50	10	50	10	50	10	0	
RCR	Zonal cavity method - Effective floor reflectance = 20%											
Room Cavity Ratio	0	119	119	119	119	116	116	111	111	106	106	100
	1	111	107	103	100	105	98	100	95	97	92	88
	2	102	96	90	85	94	84	90	82	87	80	77
	3	95	86	79	73	84	73	82	72	79	70	67
	4	88	78	70	64	76	64	74	63	72	62	60
	5	82	71	63	57	70	57	68	56	66	56	53
	6	76	64	57	51	64	51	62	50	60	50	48
	7	71	59	51	46	58	46	57	45	56	45	43
	8	67	54	47	42	54	41	53	41	51	41	39
	9	63	50	43	38	50	38	49	38	48	37	36
	10	59	47	40	35	46	35	45	34	44	34	33

Zonal lumens & percentages

Zone	Lumens	%Luminaire
0-30	286	39.5%
0-40	450	62.0%
0-60	648	89.3%
0-90	726	100.0%

CRI and CCT adjustment factors

90 CRI 2700K = 84%
80 CRI 2700K = 100%
80 CRI 3000K = 100%
80 CRI 3500K = 105%
80 CRI 4000K = 109%

Report: 1057GFR

Output lumens:	726lms	Efficacy:	79.8lm/w
Spacing Criterion:	1.2	CCT <sup>3</sup> :	4000K
Beam Angle:	87°	CRI:	80 min
Input Watts <sup>2</sup> :	9.1W		

38'x38'x10' Room, Workplane 2.5' above floor, 80/50/20% Reflectances

## S7R840K7 • 14 W LED, 90CRI, 2700 K

Candela Curves

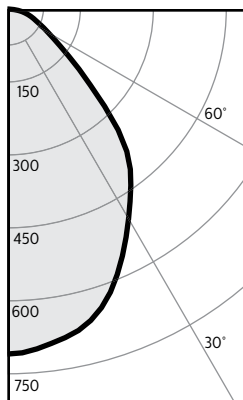

Angle	Mean CP	Lumens
0	710	
5	702	66
10	686	
15	663	186
20	620	
25	560	258
30	499	
35	443	276
40	382	
45	283	218
50	193	
55	133	122
60	97	
65	74	74
70	57	
75	44	46
80	30	
85	14	15
90	0	

Single unit data

Height to Lighted Plane	Initial center beam foot-candles	Beam dia. (ft)*
5'	28	5.5'
6'	20	6.6'
7'	14	7.7'
8'	11	8.8'
9'	9	9.9'

\* Beam diameter is where foot-candles drop to 50% of maximum.

Multiple unit data - RCR 2

Spacing on center	Initial center beam foot-candles	Watts per sq.ft.
5'	30.3	4.17
6'	19.8	2.74
7'	14.1	1.96
8'	11.8	1.63
9'	9.4	1.30

Coefficients of utilization

Ceiling	80%					70%		50%		30%		0%
	70	50	30	10	50	10	50	10	50	10	0	
Wall	70	50	30	10	50	10	50	10	50	10	0	
RCR	Zonal cavity method - Effective floor reflectance = 20%											
Room Cavity Ratio	0	119	119	119	119	116	116	111	111	106	106	100
	1	111	107	103	100	104	98	100	95	96	92	88
	2	102	96	90	85	94	84	90	82	87	80	77
	3	95	86	79	74	85	73	82	72	79	71	67
	4	88	78	70	65	77	64	74	63	72	62	60
	5	82	71	63	57	70	57	68	56	66	56	53
	6	76	65	57	51	64	51	62	51	61	50	48
	7	71	59	52	46	59	46	57	46	56	45	43
	8	67	55	47	42	54	42	53	42	52	41	39
	9	63	51	43	38	50	38	49	38	48	38	36
	10	59	47	40	35	47	35	46	35	45	35	33

Zonal lumens & percentages

Zone	Lumens	%Luminaire
0-30	510	40.4%
0-40	786	62.3%
0-60	1127	89.3%
0-90	1262	100.0%

CRI and CCT adjustment factors

90 CRI 2700K = 84%
80 CRI 2700K = 100%
80 CRI 3000K = 100%
80 CRI 3500K = 105%
80 CRI 4000K = 109%

Report: 963GFR

Output lumens:	1262lms	Efficacy:	94.2lm/w
Spacing Criterion:	1.1	CCT <sup>3</sup> :	4000K
Beam Angle:	83°	CRI:	80 min
Input Watts <sup>2</sup> :	13.4W		

38'x38'x10' Room, Workplane 2.5' above floor, 80/50/20% Reflectances

1. Tested using absolute photometry as specified in LM79: IESNA Approved Method for the Electrical and Photometric Measurements of Solid-State Lighting Products.
2. Wattage: controlled to within 5%
3. Correlated Color Temperature: within specs as defined in ANSI\_NEMA\_ANSI C78.377-2008: Specifications for the Chromaticity of Solid State Lighting Products.

© 2016 Philips Lighting Holding B.V. All rights reserved. Philips reserves the right to make changes in specifications and/or to discontinue any product at any time without notice or obligation and will not be liable for any consequences resulting from the use of this publication.



Philips Lighting North America Corporation  
200 Franklin Square Drive, Somerset, NJ 08873  
Tel. 855-486-2216

Philips Lighting Canada Ltd.  
281 Hillmount Rd, Markham, ON, Canada L6C 2S3  
Tel. 800-668-9008