



Gardco PureForm LED post top features a sleek, low profile design. Comfort optics are designed to enhance visual comfort by reducing glare. Type 1, 2, 3, and 5 optical distributions are available with lumen output up to 9000 lumens. A full range of control options provides additional energy savings. Optional integral emergency battery backup is available for path-of-egress illumination.

Project: _____
 Location: _____
 Cat.No: _____
 Type: _____
 Lamps: _____ Qty: _____
 Notes: _____

Ordering guide

example: PPT-140L-450-NW-G2-T3-1-UNV-DGY

| Prefix | Number of LEDs | Drive Current | LED Color - Generation | Mounting | Distribution | Emergency | Voltage |
|---------------------------------------|----------------------|---|--|---|--|---|--|
| PPT | | | | | | | |
| PPT PureForm post top, comfort optics | 140L 140 LEDs | 450 450mA 650 650mA 1150 1150mA ¹ 1675 1675mA ¹ 2100 2100mA ^{1,2} | WW-G2 Warm White 3000K, 70 CRI Generation 2 NW-G2 Neutral White 4000K, 70 CRI Generation 2 CW-G2 Cool White 5000K, 70 CRI Generation 2 WY-G2 Warm Yellow 2700K, 80 CRI Generation 2 ³ BW-G2 Balanced White 3500K (80 CRI) Generation 2 ³ AM-G2 Amber Generation 2 ^{3,12} | T3 Mounts to a 3" x 4" Tenon (standard) T2 Mounts to a 2-3/8" x 4" Tenon (must be ordered and shipped as a separate accessory) | 1 Comfort Type 1 2 Comfort Type 2 3 Comfort Type 3 5 Comfort Type 5 | Leave blank for no battery EBPC Emergency battery pack cold weather ^{2,4,5,6,7} EBP Emergency battery pack ^{14,5,7} | 120 120V 208 208V 240 240V 277 277V 347 347V 480 480V UNV 120-277V (50/60Hz) HVU 347-480V (50/60Hz) |

| Options | | | | |
|--|--|---|---|--|
| Dimming controls | Motion sensing | Photo-sensing | Electrical | Finish |
| DD 0-10V External dimming (by others) ⁴ FAWS Field Adjustable Wattage Selector ^{4,5} SW Interface module for SiteWise ^{4,6,8} LLC Integral wireless module ^{4,6,7,14} BL Bi-level functionality ⁴ DynaDimmer: Automatic Profile Dimming ^{4,7} CS50 Security 50% Dimming, 7 hours CM50 Median 50% Dimming, 8 hours CE50 Economy 50% Dimming, 9 hours DA50 All Night 50% Dimming CS30 Security 30% Dimming, 7 hours CM30 Median 30% Dimming, 8 hours CE30 Economy 30% Dimming, 9 hours DA30 All Night 30% Dimming | IMRI3 Integral with #3 lens ¹³ | PCB Photocontrol Button ^{7,9} TLRD5 Twist Lock Receptacle 5 Pin ¹⁰ TLRD7 Twist Lock Receptacle 7 Pin ¹⁰ TLRPC Twist Lock Receptacle w/Photocell ^{9,11} | Fusing F1 Single (120, 277, 347VAC) ⁹ F2 Double (208, 240, 480VAC) ⁹ F3 Canadian Double Pull (208, 240, 480VAC) ⁹ Surge Protection (10kA standard) SP2 Increased 20kA | Textured BK Black WH White BZ Bronze DGY Dark Gray MGY Medium Gray Customer specified RAL Specify optional color or RAL (ex: RAL7024) CC Custom color (Must supply color chip for required factory quote) |

- 1150, 1675, and 2100mA not available with emergency battery backup (EBP).
- 2100mA not available with emergency battery backup cold weather (EBPC).
- Extended lead times apply. Contact factory for details.
- Not available with other control options.
- Not available with motion sensor.
- Not available with photocontrol.
- Not available in 347 or 480V.
- Available only in 120 or 277V.
- Must specify input voltage.
- Dimming will not be connected to NEMA receptacle if ordering with other control options.
- Not available in 480V.
- Not available in 2100mA.
- Not available with DD and FAWS dimming control options.
- Must specify a motion sensor lens.



PPT PureForm LED post top

with comfort optics

PureForm Accessories (order separately)

PPT-T2

Post top tenon adapter for 2 3/8" x 4"

FSIR-100

BL Optional Remote Programming Tool

LED Wattage and Lumen Values – 3000K

| Ordering Code | Total LEDs | LED Current (mA) | Color Temp. | Average System Watts | Type 1 | | | Type 2 | | | Type 3 | | | Type 5 | | |
|---------------------------|------------|------------------|-------------|----------------------|--------------|------------|----------------|--------------|------------|----------------|--------------|------------|----------------|--------------|------------|----------------|
| | | | | | Lumen Output | BUG Rating | Efficacy (LPW) | Lumen Output | BUG Rating | Efficacy (LPW) | Lumen Output | BUG Rating | Efficacy (LPW) | Lumen Output | BUG Rating | Efficacy (LPW) |
| PPT-140L-450-WW-G2-x-UNV | 140 | 450 | 3000 | 22 | 1903 | B1-U0-G1 | 85 | 1884 | B1-U0-G1 | 84 | 2338 | B1-U0-G1 | 105 | 2176 | B1-U0-G1 | 98 |
| PPT-140L-650-WW-G2-x-UNV | 140 | 650 | 3000 | 30 | 2545 | B1-U0-G1 | 84 | 2519 | B1-U0-G1 | 83 | 3126 | B1-U0-G1 | 103 | 2910 | B2-U0-G1 | 96 |
| PPT-140L-1150-WW-G2-x-UNV | 140 | 1150 | 3000 | 52 | 4573 | B2-U0-G2 | 88 | 4525 | B2-U0-G2 | 87 | 5616 | B2-U0-G2 | 108 | 5229 | B3-U0-G2 | 100 |
| PPT-140L-1675-WW-G2-x-UNV | 140 | 1675 | 3000 | 75 | 6348 | B3-U0-G3 | 84 | 6282 | B2-U0-G2 | 83 | 7796 | B2-U0-G3 | 103 | 7258 | B3-U0-G2 | 96 |
| PPT-140L-2100-WW-G2-x-UNV | 140 | 2100 | 3000 | 96 | 7600 | B3-U0-G3 | 79 | 7521 | B3-U0-G3 | 78 | 8701 | B3-U0-G3 | 91 | 8689 | B3-U0-G2 | 91 |

LED Wattage and Lumen Values – 4000K

| Ordering Code | Total LEDs | LED Current (mA) | Color Temp. | Average System Watts | Type 1 | | | Type 2 | | | Type 3 | | | Type 5 | | |
|---------------------------|------------|------------------|-------------|----------------------|--------------|------------|----------------|--------------|------------|----------------|--------------|------------|----------------|--------------|------------|----------------|
| | | | | | Lumen Output | BUG Rating | Efficacy (LPW) | Lumen Output | BUG Rating | Efficacy (LPW) | Lumen Output | BUG Rating | Efficacy (LPW) | Lumen Output | BUG Rating | Efficacy (LPW) |
| PPT-140L-450-NW-G2-x-UNV | 140 | 450 | 4000 | 22 | 1971 | B1-U0-G1 | 88 | 1951 | B1-U0-G1 | 87 | 2421 | B1-U0-G1 | 109 | 2254 | B1-U0-G1 | 101 |
| PPT-140L-650-NW-G2-x-UNV | 140 | 650 | 4000 | 30 | 2636 | B1-U0-G1 | 87 | 2609 | B1-U0-G1 | 86 | 3237 | B1-U0-G1 | 106 | 3014 | B2-U0-G1 | 99 |
| PPT-140L-1150-NW-G2-x-UNV | 140 | 1150 | 4000 | 52 | 4736 | B2-U0-G2 | 91 | 4686 | B2-U0-G2 | 90 | 5816 | B2-U0-G2 | 111 | 5415 | B3-U0-G2 | 104 |
| PPT-140L-1675-NW-G2-x-UNV | 140 | 1675 | 4000 | 75 | 6574 | B3-U0-G3 | 87 | 6506 | B2-U0-G2 | 86 | 8074 | B2-U0-G3 | 106 | 7517 | B3-U0-G2 | 99 |
| PPT-140L-2100-NW-G2-x-UNV | 140 | 2100 | 4000 | 96 | 7871 | B3-U0-G3 | 82 | 7789 | B3-U0-G3 | 81 | 9011 | B3-U0-G3 | 94 | 8999 | B3-U0-G2 | 94 |

LED Wattage and Lumen Values – 5000K

| Ordering Code | Total LEDs | LED Current (mA) | Color Temp. | Average System Watts | Type 1 | | | Type 2 | | | Type 3 | | | Type 5 | | |
|---------------------------|------------|------------------|-------------|----------------------|--------------|------------|----------------|--------------|------------|----------------|--------------|------------|----------------|--------------|------------|----------------|
| | | | | | Lumen Output | BUG Rating | Efficacy (LPW) | Lumen Output | BUG Rating | Efficacy (LPW) | Lumen Output | BUG Rating | Efficacy (LPW) | Lumen Output | BUG Rating | Efficacy (LPW) |
| PPT-140L-450-CW-G2-x-UNV | 140 | 450 | 5000 | 22 | 2050 | B1-U0-G1 | 92 | 2029 | B1-U0-G1 | 91 | 2518 | B1-U0-G1 | 113 | 2344 | B2-U0-G1 | 105 |
| PPT-140L-650-CW-G2-x-UNV | 140 | 650 | 5000 | 30 | 2741 | B1-U0-G1 | 90 | 2713 | B1-U0-G1 | 89 | 3366 | B1-U0-G2 | 111 | 3135 | B2-U0-G1 | 103 |
| PPT-140L-1150-CW-G2-x-UNV | 140 | 1150 | 5000 | 52 | 4925 | B2-U0-G2 | 94 | 4873 | B2-U0-G2 | 93 | 6049 | B2-U0-G2 | 116 | 5632 | B3-U0-G2 | 108 |
| PPT-140L-1675-CW-G2-x-UNV | 140 | 1675 | 5000 | 75 | 6837 | B3-U0-G3 | 90 | 6766 | B3-U0-G3 | 89 | 8397 | B3-U0-G3 | 111 | 7818 | B3-U0-G2 | 103 |
| PPT-140L-2100-CW-G2-x-UNV | 140 | 2100 | 5000 | 96 | 8186 | B3-U0-G3 | 85 | 8101 | B3-U0-G3 | 85 | 9372 | B3-U0-G3 | 98 | 9359 | B3-U0-G2 | 98 |

Values from photometric tests performed in accordance with IESNA LM-79 and are representative of the configurations shown. Actual performance may vary due to installation and environmental variables, LED and driver tolerances, and field measurement considerations. It is highly recommended to confirm performance with a photometric layout.

NOTE: Some data may be scaled based on tests of similar (but not identical) luminaires. Contact factory for configurations not shown.

LED Wattage and lumen values (Emergency Mode)

| Ordering Code | LED Qty | LED Current (mA) | Color Temp. | Temp. Range (°C) | Lumen Outputs | | | | | | | | | |
|--------------------------------|---------|------------------|-------------|------------------|-------------------|----------------|-------------|----------------|-------------|----------------|-------------|----------------|-------------|----------------|
| | | | | | Avg. System Watts | | Type 1 | | Type 2 | | Type 3 | | Type 5 | |
| | | | | | Normal Mode | Emergency Mode | Normal Mode | Emergency Mode | Normal Mode | Emergency Mode | Normal Mode | Emergency Mode | Normal Mode | Emergency Mode |
| PPT-140L-450-NW-G2-x-EBP-UNV | 140 | 450 | 4000 | 0 to 40 | 22 | 10 | 1971 | 1526 | 1951 | 1510 | 2421 | 1747 | 2254 | 1744 |
| PPT-140L-650-NW-G2-x-EBP-UNV | 140 | 650 | 4000 | 0 to 40 | 30 | 10 | 2636 | 1526 | 2609 | 1510 | 3237 | 1747 | 3014 | 1744 |
| PPT-140L-450-NW-G2-x-EBPC-UNV | 140 | 450 | 4000 | -20 to 40 | 22 | 18 | 1971 | 2178 | 1951 | 2155 | 2421 | 2493 | 2254 | 2490 |
| PPT-140L-650-NW-G2-x-EBPC-UNV | 140 | 650 | 4000 | -20 to 40 | 30 | 18 | 2636 | 2178 | 2609 | 2155 | 3237 | 2493 | 3014 | 2490 |
| PPT-140L-1150-NW-G2-x-EBPC-UNV | 140 | 1150 | 4000 | -20 to 40 | 52 | 18 | 4736 | 2178 | 4686 | 2155 | 5816 | 2493 | 5415 | 2490 |
| PPT-140L-1675-NW-G2-x-EBPC-UNV | 140 | 1675 | 4000 | -20 to 40 | 75 | 18 | 6574 | 2178 | 6506 | 2155 | 8074 | 2493 | 7517 | 2490 |

For emergency EBPC and EBP option, published values are based on initial lumens.

Predicted Lumen Depreciation Data

Predicted performance derived from LED manufacturer's data and engineering design estimates, based on IESNA LM-80 methodology. Actual experience may vary due to field application conditions. L70 is the predicted time when LED performance depreciates to 70% of initial lumen output. Calculated per IESNA TM21-11. Published L70 hours limited to 6 times actual LED test hours

| Ambient Temperature °C | Driver mA | Calculated L70 Hours | L70 per TM-21 | Lumen Maintenance % at 60,000 hrs |
|------------------------|--------------|----------------------|---------------|-----------------------------------|
| 25°C | up to 2100mA | >100,000 hours | >60,000 hours | >84% |

PPT PureForm LED post top

with comfort optics

Dimensions – Post Top Luminaire

Effective Projected Area ft² / m²

| | |
|------|---|
| Type | Single |
| PPT | 0.35 ft ² /0.032m ² |

Approximate Motion Sensor Placement

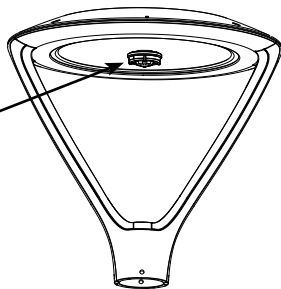

Front View

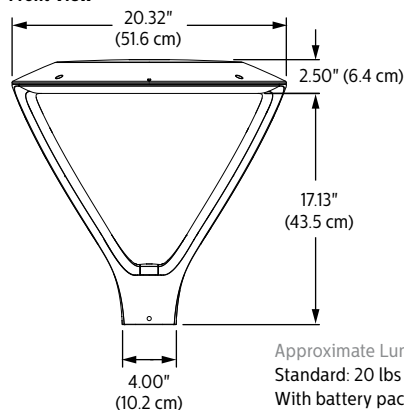

Side View

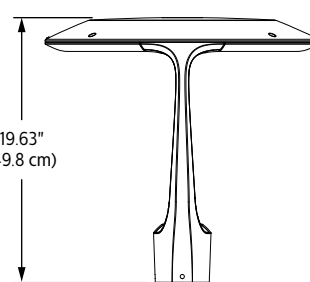

Approximate Luminaire Weight:
Standard: 20 lbs (9.1 kg)
With battery pack: 26 lbs (11.8 kg)

Optical Distributions

Based on 20' mounting height

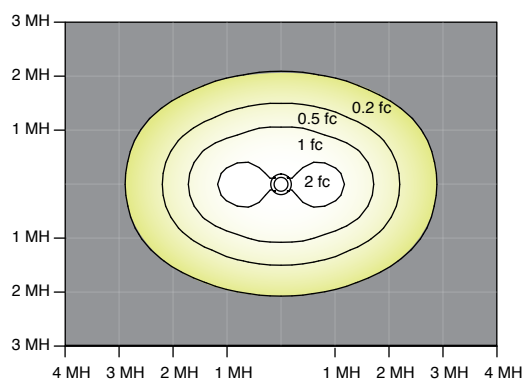

Comfort Type 1

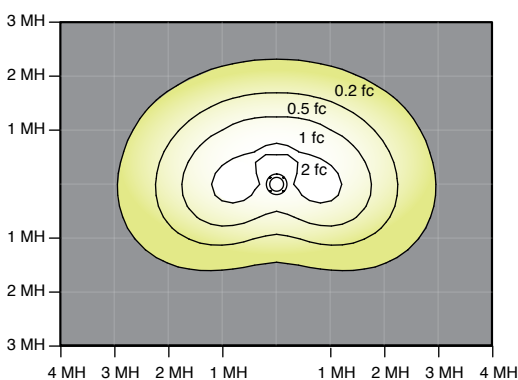

Comfort Type 2

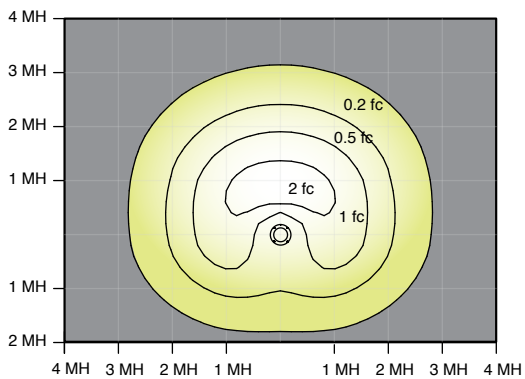

Comfort Type 3

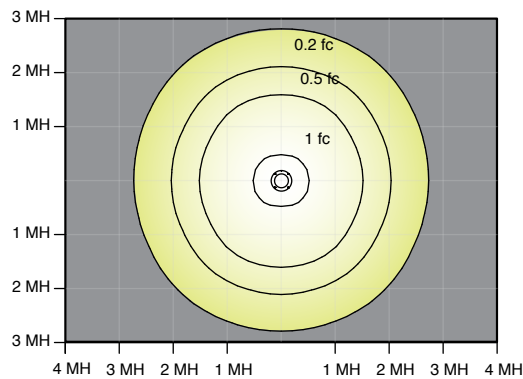

Comfort Type 5

Asymmetric Optical Orientation Information

Standard Optic Position

Aimed Between The Yoke Supports

Luminaires ordered with asymmetric optical systems in the standard optic position will have the optical system oriented as shown below:

Symbol to indicate the direction of the street side

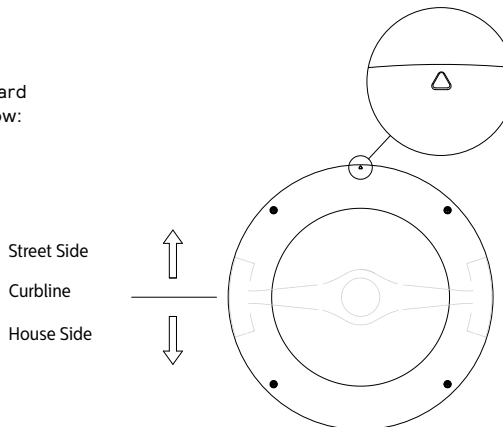

PPT PureForm LED post top

with comfort optics

Specifications

Housing

Two-piece sealed enclosure with main part of the housing designed as the structural and heat sink frame, enclosed by cover to give its unique form. It also includes yoke arm with arm covers. All die-cast parts are made of low-copper, die-cast aluminum alloy for a high resistance to corrosion. The sleek profile with optimized surface area allows housing to provide excellent convection heat transfer with minimum use of heat fins, giving the freedom to have a clean minimalist aesthetic design. Luminaire housing rated to IP66, tested in accordance to Section 9 of IEC 60598-1.

Vibration resistance

Luminaire is tested and rated 3G over 100,000 cycles conforming to standards set forth by ANSI C136.31-2010. Testing includes vibration to 3G acceleration in three axes, all performed on the same luminaire.

Light engine

Light guide technology provides low-glare, uniform illumination. Composed of 140 LEDs strategically positioned on the edge of the optical plate. Light engine luminous opening size optimized to best achieve a balance between lumen output and optical performance with the need to provide visual comfort. Light engine frame ensures contact with housing to provide heat conduction and sealing against the elements. Light engine is RoHS compliant. Standard color temperatures: 3000K +/- 130K, 4000K +/- 130K, 5000K +/- 225K. Minimum CRI of 70. Also available in 2700K and Amber (Dominant wavelength 589nm, peak wavelength 633nm, and minimum wavelength 486nm) with extended lead times. Contact factory for details.

Energy saving benefits

System efficacy up to 111 lms/W with significant energy savings over Pulse Start Metal Halide luminaires. Optional control options provide added energy savings during unoccupied periods.

Optical systems

The advanced LED comfort optical system provides Types 1, 2, 3, and 5. Composed of high performance UV-stabilized optical grade lens with molded micro-optics to achieve desired distribution optimized to get a exceptional lighting uniformity. Performance tested per LM-79 and TM-15 (IESNA) certifying its photometric performance. Luminaire designed with 0% uplight (U0 per IESNA TM-15).

Mounting

PureForm Post Top mounts standard to a 3" x 4" Tenon, but can also be mounted to a 2-3/8" x 4" Tenon if a separate sleeve is ordered as an accessory.

Control options

0-10V dimming (DD): Access to 0-10V dimming leads supplied through the yoke of the luminaire (for secondary dimming controls by others). Cannot be used with other control options.

SiteWise (SW): SiteWise system includes a controller fully integrated in the luminaire that enables the luminaires to communicate with a dimming signal transmitter cabinet located on site using patented central dimming technology. A locally accessible mobile app allows users to access the system and set functionalities such as ON/OFF, dimming levels and scheduling. SiteWise is available with motion response options in order to bring the light back to 100% when motion is detected. Cannot be used with other control options or photocell options. Additional functionalities are available such as communication with indoor lighting and connection to BMS systems. Complete information on the control system can be found on the SiteWise website at philips.com/sitewise.

Field Adjustable Wattage Selector (FAWS): Luminaire equipped with the ability to manually adjust the wattage in the field to reduce total luminaire lumen output and light levels. Comes pre-set to the highest position at the lumen output selected. Use chart below to estimate reduction in lumen output desired. Cannot be used with other control options or motion response.

| FAWS Position | Percent of Typical Lumen Output |
|---------------|---------------------------------|
| 1 | 25% |
| 2 | 50% |
| 3 | 55% |
| 4 | 65% |
| 5 | 75% |
| 6 | 80% |
| 7 | 85% |
| 8 | 90% |
| 9 | 95% |
| 10 | 100% |

Note: Typical value accuracy +/- 5%

Automatic Profile Dimming (CS/CM/CE/CA): Standard dimming profile of 30% or 50% provide flexibility towards energy savings goals while optimizing light levels during specific dark hours. When used in combination with not programmed motion response it overrides the controller's schedule when motion is detected. After 5 minutes with no motion, it will return to the automatic dimming profile schedule. Automatic dimming profile scheduled with the following settings:

- **CS50/CS30:** Security for 7 hours night duration (Ex., 11 PM - 6 AM)
- **CM50/CM30:** Median for 8 hours night duration (Ex., 10 PM - 6 AM)
- **CE50/CE30:** Economy for 9 hours night duration (Ex., 9 PM - 6 AM)
- **CA50/CA30:** for all night (during all dark hours)

All above profiles are calculated from mid point of the night. Dimming is set for 6 hours after the mid point and 1, 2, or 3 hours before depending of the duration of dimming. Cannot be used with other dimming control options.

Emergency Battery Backup (EBP/EBPC): Emergency battery packs included integral to the luminaire, allowing for a consistent look between emergency and non-emergency luminaires. EBP is suitable for use in ambient temperature conditions from 0°C (32°F) to 40°C (104°F) available on 450mA and 650mA only. EBPC cold weather rated down to -20°C (-4°F) available on all wattage except the 2100mA configuration. Both systems are designed to have a secondary driver with relay to immediately detect AC power loss to power luminaire for a minimum of 90 minutes from the time power is lost. Available with 120-277V, or 'UNV' only.

Wireless system (LLC): Optional wireless controller integral to luminaire ready to be connected to a Lighthouse system (sold by others). The system allows you to wirelessly manage the entire site, independent lighting groups or individual luminaires while on-site or remotely. Based on a high-density mesh network with an easy to use web-based portal, you can conveniently access, monitor and manage your lighting network remotely. Wireless controls can be combined with site and area, pedestrian, and parking garage luminaires as well, for a completely connected outdoor solution. Equipped with motion response with #3 lens (LLC3-IMR13) for 8-25' mounting heights. Also available with remote pod accessory where pod is mounted separate from luminaire to pole or wall.

LLC-IMR13 Luminaire with #3 lens

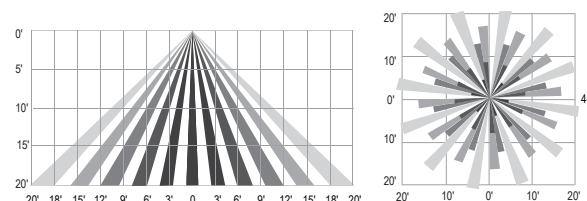

PPT PureForm LED post top

with comfort optics

Motion response options

Bi-Level Infrared Motion Response (BL-IMRI3): Motion Response module is mounted integral to luminaire factory pre-programmed to 50% dimming when not ordered with other control options. BL-IMRI3 is set/operates in the following fashion: The motion sensor is set to a constant 50%. When motion is detected by the PIR sensor, the luminaire returns to full power/light output. Dimming on low is factory set to 50% with 5 minutes default in "full power" prior to dimming back to low. When no motion is detected for 5 minutes, the motion response system reduces the wattage by 50%, to 50% of the normal constant wattage reducing the light level. Other dimming settings can be provided if different dimming levels are required. This can also be done with FSIR-100 Wireless Remote Programming Tool (contact Technical Support for details).

Infrared Motion Response with Other Controls (SW-IMRI3): When used in combination with other controls (Automatic Dimming Profile and SiteWise), motion response device will simply override controller's schedule with the added benefits of a combined dimming profile and sensor detection. In this configuration, the motion response device cannot be re-programmed with FSIR-100 Wireless Remote Programming Tool. The profile can only be re-programmed via the controller.

Infrared Motion Response Lenses (IMRI3): Infrared Motion Response Integral module is available lens #3 (IMRI3), which is designed for mounting heights up to 20' with a 40' diameter coverage area. See chart for approximate detection patterns:

IMRI3 Luminaire with #3 lens

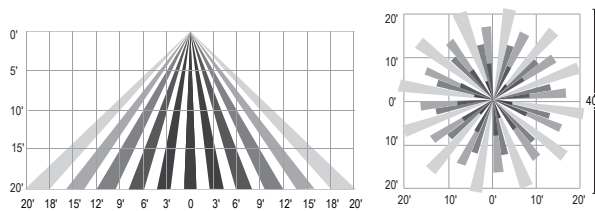

Surge protection (SP1/SP2): Surge protection device tested in accordance with ANSI/IEEE C62.45 per ANSI/IEEE C62.41.2 Scenario I Category C High Exposure 10kV/10kA waveforms for Line-Ground, Line-Neutral and Neutral-Ground, and in accordance with DOE MSSLC Model Specification for LED Roadway Luminaires Appendix D Electrical Immunity High test level 10kV/10kA. 20kV / 10kA surge protection device that provides extra protection beyond the SP1 10kV/10kA level.

Listings

UL/cUL wet location listed to the UL 1598 standard, suitable for use in ambient temperatures from -40° to 40°C (-40° to 104°F). Most PureForm PPT comfort configurations are qualified under Standard DesignLights Consortium® category. Consult DLC Qualified Products list to confirm your specific luminaire selection is approved. CCTs 3000K and warmer are Dark Sky Approved.

Finish

Each standard color luminaire receives a fade and abrasion resistant, electrostatically applied, thermally cured, triglycidal isocyanurate (TGIC) textured polyester powdercoat finish. The surface treatment achieves a minimum of 1000 hours for salt spray resistant finish in accordance with testing performed and per ASTM B117 standard. Standard colors include bronze (BZ), black (BK), white (WH), dark gray (DGY), and medium gray (MGY). Consult factory for specs on optional or custom colors.

Warranty

PureForm luminaires feature a 5-year limited warranty. See signify.com/warranties for complete details and exclusions.

Electrical

Twist-Lock Receptacle (TLRD5/TLRD7/ TLRPC): Twist Lock Receptacle with 5 pins enabling dimming or with 7 pins with additional functionality (by others) can be used with a twistlock photoelectric cell or a shorting cap. Dimming Receptacle Type B (5-pin) and Type D-24 (7-pin) in accordance to ANSI C136.41. Can be used with third-party control system. Receptacle located on top of luminaire housing. When specifying receptacle with twistlock photoelectric cell, voltage must be specified. When ordering Twist-lock receptacle (TLRD5 or TLRD7), photocell or shorting cap is not included.

Driver: Driver efficiency (>90% standard). 120-480V available (restrictions apply). Open/short circuit protection. Optional 0-10V dimming to 10% power. RoHS compliant.

Button Photocontrol (PCB): Button style design for internal luminaires mounting applications. The photocontrol is constructed of a high impact UV stabilized polycarbonate housing. Rated voltage of 120V or 208-277V with a load rating of 1000 VA. The photocell will turn on with 1-4Fc of ambient light.

The information presented in this document is not intended as any commercial offer and does not form part of any quotation or contract.

