



PL-S Blacklight Blue

PL-S 9W BLB/4P 1CT

PL-S Blacklight Blue is a special low-wattage compact fluorescent lamp emitting long wave UV radiation for detection and analysis purposes in archaeology, money checking, forensic science, food industry, medicine, mineralogy, philately as well for special effects in night clubs, discos, theatres and sign lighting. The 2-pin version is designed for operation on electromagnetic gear, the 4-pin version is designed for operation on electronic gear. Both versions are provided with a plug-in/pull-out lamp base.

Product data

• General Characteristics

Cap-Base	2G7
Cap-Base Information	4 Pins
Bulb	2xT12
Main Application	Blacklight Blue
Useful Life	8000 hr

• Light Technical Characteristics

Color Code	108 [08 lead free glass]
Color Designation (text)	Blacklight Blue

• Electrical Characteristics

Lamp Wattage	9 W
Lamp Wattage Technical	8.6 W
Lamp Voltage	60 V
Lamp Current	0.17 A

• Environmental Characteristics

Mercury (Hg) Content	3.0 mg
----------------------	--------

• UV-related Characteristics

UV-A Power (IEC)	1.65 W
UV-B/UV-A (IEC)	0.2 %

• Product Dimensions

Base Face to Base Face A	128.0 (max) mm
Insertion Length B	145.0 (max) mm
Overall Length C	152.0 (max) mm
Diameter D	28.0 (max) mm
Diameter D1	13.0 (max) mm

• Product Data

Order code	927901910807
Full product code	927901910807
Full product name	PL-S 9W BLB/4P 1CT
Order product name	PL-S 9W BLB/4P 1CT/6X10CC
Pieces per pack	1
Packing configuration	6X10CC
Packs per outerbox	60
Bar code on pack - EAN1	8711500950932
Bar code on intermediate packing - EAN2	8711500950949
Bar code on outerbox - EAN3	8711500950956
Logistic code(s) - 12NC	927901910807
Net weight per piece	29.500 gr

PHILIPS

Dimensional drawing

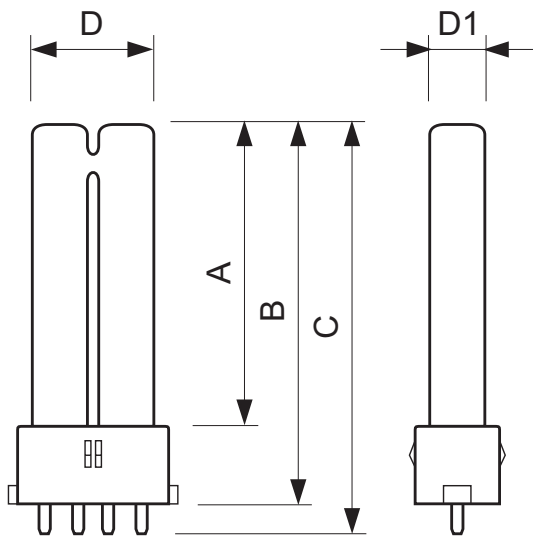

PL-S 9W BLB/4P 1CT

Product	B (Max)	D1 (Max)
PL-S 9W/108/4P	145.0	13.0

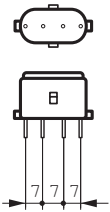

2G7



© 2014 Koninklijke Philips N.V. (Royal Philips)
All rights reserved.

Specifications are subject to change without notice. Trademarks are the property of Koninklijke Philips N.V. (Royal Philips) or their respective owners.

www.philips.com/lighting

2014, April 11
data subject to change