

OVERVIEW

The MSOD Series sensor provides both Motion and Daylight based control of a 0-10 VDC dimmable outdoor or wet location luminaire. For motion detection, the sensor utilizes 100% Digital Passive Infrared (PIR) technology that is tuned for walking size motion while preventing false tripping from the environment. The unit's integrated photocell enables additional energy savings during daytime periods when there is sufficient daylight.

FEATURES

- 100% Digital PIR Detection, Excellent RF Immunity
- Integrated Photocell
- 0-10 VDC Control Output
- Gasketed for Outdoor Operation
- Two Piece Snap-Together Assembly Compatible w/ 0-10 VDC Dimmable Ballasts and LED Drivers
- Adjustable Time Delays, Max/Min Dim Levels, and Ramp Rates
- Programming Button Accessible w/o Opening Sensor or Removing Gasketing
- No Field Calibration or Sensitivity Adjustments Required
- Non-Volatile Settings Memory
- Convenient Test Mode
- Green LED Indicator
- Configurable using the SensorSwitch Mobile App

Warranty

Three-year limited warranty. This is the only warranty provided and no other statements in this specification sheet create any warranty of any kind. All other express and implied warranties are disclaimed. Complete warranty terms located at: www.acuitybrands.com/support/warranty/terms-and-conditions

Note: Actual performance may differ as a result of end-user environment and application. Specifications subject to change without notice.



*MSOD
Outdoor Embedded
360° Motion Sensor*



ORDERING INFORMATION

MSOD 7 ODP							Example: MSOD 7 ODP WH 2V						
Series	Coverage Type	eldoLED Compatibility		PIR Detection Type		Visible Light Programming		Color		Min Dim Level ¹			
MSOD Outdoor Embedded Motion Sensor	7 Mini Low-Bay	[blank]	None	ODP Outdoor PIR w/ Photocell	[blank]	None	VLP	WH	White	1V	1 VDC	4V	4 VDC
	30 Universal	EZ	eldoLED Driver Compatible					BK	Black	2V	2 VDC	5V	5 VDC
									3V	3 VDC	0V	~0 VDC	

Note:
1. Not available with EZ option.

DIMENSIONS

Dimensions
in inches

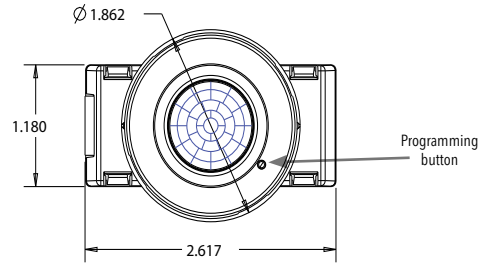
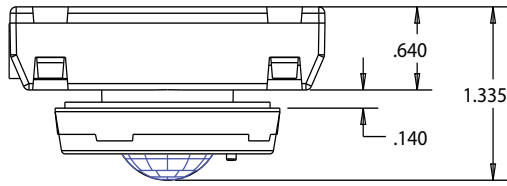

COVERAGE PATTERNS

LOW BAY 360° LENS - MSOD 7

HIGH VIEW

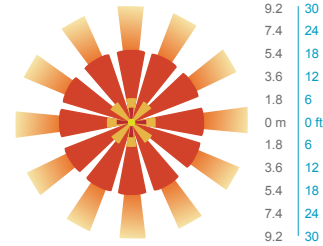
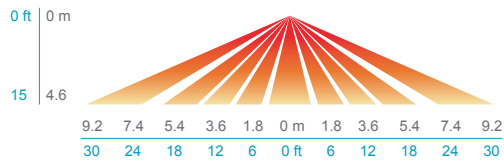

UNIVERSAL 360° LENS - MSOD 30

SIDE VIEW

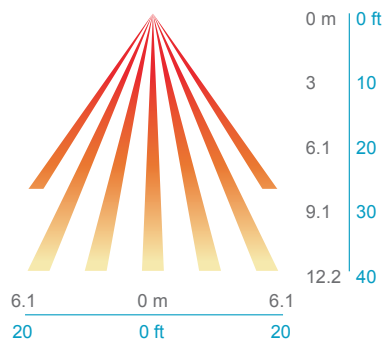

TOP VIEW

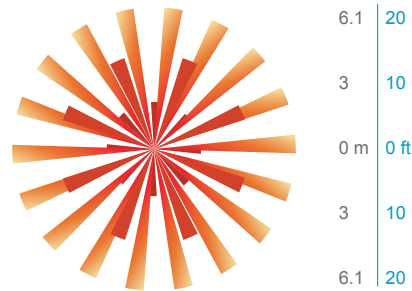

WIRING

RED – 12-24 VDC Power Input

VIOLET – Low Voltage Dim Output (0-10 VDC)

BLACK – Low Voltage Common

Note: Do not connect the dimming wires of multiple sensors in parallel.

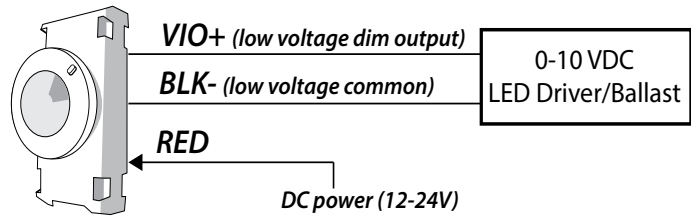

INSTALLATION

- If not pre-installed, locate sensor body so that detector faces down through 1.125" hole in luminaire.
- Install gasket around detector on outside of luminaire.
- Align lens assembly legs with holes in sensor body and snap together (max material thickness 0.15").
- Apply foam spacer pads onto sensor body if needed to ensure snug fit with fixture.
- Assembly rotates 15° to enable coverage pattern adjustment after installation.
- To unsnap lens assembly, pry up under lip on sides at spots on lens assembly denoted by arrows.

**DIAGRAM 1.
INSTALLATION EXAMPLE**

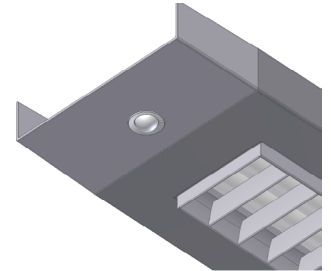

**DIAGRAM 2.
ASSEMBLY DETAIL**

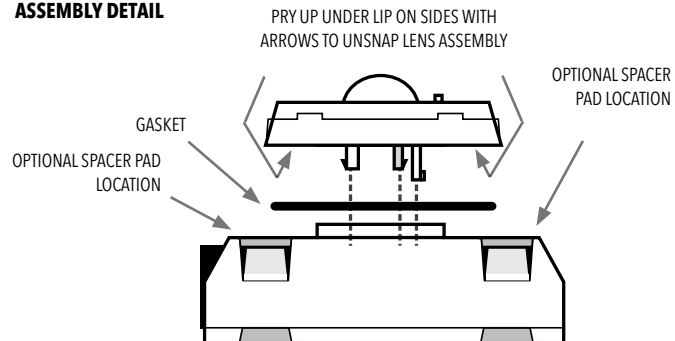

PROGRAMMING INSTRUCTIONS

Please read all 3 steps before programming

1. Enter a programming function by pressing button the number of times as the desired function number from the tables on the right (e.g., press twice for function 2, motion time delay).
2. LED will flash back the selected function's current setting (e.g., 3 flashes for 5 minute time delay). To change setting, proceed to step 3 before flash back sequence repeats 3 times. To exit the current function or to change to a different function, wait for sequence to repeat 3 times then return to step 1.
3. Press button the number of times indicated in the particular function's detailed table for the NEW desired setting (e.g., press 5 times for 10 min). As confirmation of setting change, LED flashes back the NEW setting 3 times before exiting.

DETAILED FUNCTION TABLES

2 = Motion Time Delay: The length of time the motion sensor will keep the lights on and at a maximum level after it last detects motion.

1	30 sec	3	5.0 min*	5	10.0 min	7	15.0 min	9	20.0 min
2	2.5 min	4	7.5 min	6	12.5 min	8	17.5 min		

4 = Test & Blink-Back Mode:

Auto set-point - Photocell calibration procedure for detecting optimum lighting control level. Blink-back mode - The type of visual feedback that is provided when programming via the push-button; i.e. entire fixture will blink or just sensor LED will blink.

Test mode - Disables minimum on time, sets motion time delay to 30 sec, and shortens all photocell transition and dimming rates. Mode will expire after 10 min or if function 4 is changed.

1	Blink Light & LED*	4	Auto-Setpoint	6	Test Mode ²
2	Blink LED only	5	Blink Set-Point ¹		

¹The LED will blink back the ten's digit, then pause, then blink back the one's digit. For a "0" the LED will blink very rapidly. The sequence is repeated 3 times.

²Test Mode will set Motion Time Delay to 30 sec, and shorten all photocell transitions and dimming rates. Mode will expire after 10 min or if function 4 is set back to previous setting.

5 = Ten's Digit of Set-Point: The ten's digit of the target light level that is to be maintained by the device (in foot-candles).

1	10 fc	3	30 fc	5	50 fc	7	200 fc
2	20 fc	4	40 fc	6	100 fc	10	0 fc*

6 = One's Digit of Set-Point: The one's digit of the target light level that is to be maintained by the device (in foot-candles).

1	1 fc	3	3 fc	5	5 fc*	7	7 fc	9	9 fc
2	2 fc	4	4 fc	6	6 fc	8	8 fc	10	0 fc

7 = Sunlight Discount Factor: Value used to improve the tracking accuracy of a photocell during the periods of high daylight. Decreasing the value will lower the controlled level of the lights.

1	x/1*	3	x/3	5	x/5	7	x/7	9	x/9
2	x/2	4	x/4	6	x/6	8	x/8	10	x/10

8 = Incremental Set-Point Adjustment: Alters the target light level that is to be maintained by the device (in foot-candles).

1	Decrease 1 fc	3	Increase 1 fc
---	---------------	---	---------------

9 = Restore Factory Defaults: Returns the sensor to its default settings.

1	Keep Current*	2	Restore Factory Defaults
---	---------------	---	--------------------------

11 = Photocell Operation: Indicates what mode of photocell operation, if any, is enabled.

1	High/Off*	2	High/Low	3	Disabled
---	-----------	---	----------	---	----------

12 = Ramp Up Rate: Time period from when motion is detected to when lights are at high trim level.

1	Instant	3	2 sec	5	5 sec	7	15 sec	9	30 sec
2	1 sec	4	3 sec*	6	10 sec	8	20 sec	10	1 min

13 = Fade Down Rate: Time period from when motion time delay expires to when lights are at low trim level.

1	Instant	3	2.5 min	5	7.5 min	7	15.0 min	9	30.0 min
2	30 sec	4	5.0 min*	6	10.0 min	8	20.0 min	10	1 hr

15 = Dimming Range (High Trim): The output level (0-10VDC) of the sensor after motion is detected.

1	Off/ 0 Volt	4	2 Volts	7	5 Volts	10	8 Volts	13	10 Volts*
2	1 Volt	5	3 Volts	8	6 Volts	11	9 Volts		
3	1.5 Volts	6	4 Volts	9	7 Volts	12	9.1 Volts**		

16 = Dimming Range (Low Trim): The output level (0-10VDC) of the sensor after the fade down time has elapsed.

1	Off/ 0 Volt	4	2 Volts	7	5 Volts	10	8 Volts	13	10 Volts
2	1 Volt*	5	3 Volts	8	6 Volts	11	9 Volts		
3	1.5 Volts**	6	4 Volts	9	7 Volts	12	9.1 Volts		

21 = Photocell Transition Off Time: The time period after the photocell measures a light level above the set-point (plus the deadband) that it will turn lights off (or dim them to min level).

1	45 sec	3	5.0 min*	5	15.0 min	7	25.0 min
2	2.0 min	4	10.0 min	6	20.0 min		

22 = Photocell Transition On Time: The time period after the photocell measures a light level below the set-point that it will turn lights on.

1	45 sec*	3	5.0 min	5	15.0 min	7	25.0 min
2	2.0 min	4	10.0 min	6	20.0 min		

* DEFAULT SETTING

** SPECIAL DEFAULT SETTING FOR -EZ UNITS

SPECIFICATIONS

Electrical

Input Ratings	12-24VDC, 4mA, Class 2
Low Voltage Output Ratings	0-10VDC, 17mA max
Standards/ Ratings	Energy Management Equipment, UL916 (E167435)

Mechanical

Dimensions	2.62H" x 1.18W" x 1.34D" (67mm x 30mm x 34mm)
Mounting	Fixture Integrated Required hole size of 1.125" and material thickness of 0.25" max
Connection Type	Low Voltage Leads

Environmental

Warrantied Operating Temperature	-4°F to 140°F (-20°C to 60°C)
Relative Humidity	Up to 90%, Non-Condensing
Environment	Indoor/Outdoor
Standards/ Ratings	IP65 Rated, RoHS