

LMRC-213

Digital Lighting Management (DLM)

Triple Relay w/0-10V Dimming Room Controller

**THIS UNIT IS SET FOR
PLUG n' GO™
OPERATION,
ADJUSTMENT IS
OPTIONAL.**

For full operational details see the DLM Dimming System Installation Guide provided with the room controller and also available at www.wattstopper.com



Patent Pending

INSTALLATION SHALL BE IN ACCORDANCE WITH ALL APPLICABLE REGULATIONS, LOCAL AND NEC CODES.

Wire connections shall be rated suitable for the wire size (lead and building wiring) employed.

Specifications

Input Voltage	120/277VAC, 50/60Hz
Load Requirements	Not to exceed 20A total
Each relay rated for up to:	
Incandescent	20A @ 120VAC
Ballast	20A @ 120/277VAC
Motor	1Hp @ 120VAC
Output to DLM Local Network	up to 250mA @ 24VDC
Class 2 Dimming Outputs (3) 0-10V	sink up to 100mA per channel
DLM Local Network Characteristics when using LMRC-213:	
Provides low voltage power over Cat 5e cable (LMRJ); max current 800mA. Supports up to 64 load addresses, 48 communicating devices including up to 4 LMRC-10x series and/or LMPL-101 controllers. Free topology up to 1,000' max.	
Environment:	
Operating Temperature	32° to 158°F (0° to 70°C)
Storage Temperature	23° to 176°F (-5° to 80°C)
Relative Humidity	5 to 95% (non condensing)

PLACEMENT EXAMPLE

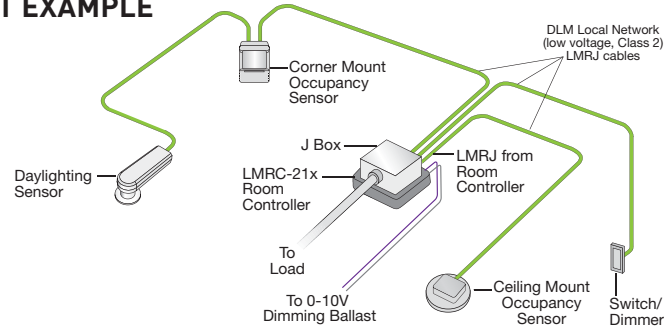

CAUTION: TURN THE POWER OFF AT THE CIRCUIT BREAKER BEFORE WIRING.

WARNING: TO CONNECT A COMPUTER TO THE DLM LOCAL NETWORK USE THE LMCI-100. NEVER CONNECT THE DLM LOCAL NETWORK TO AN ETHERNET PORT - IT MAY DAMAGE COMPUTERS AND OTHER CONNECTED EQUIPMENT.

CONNECTIVITY

The LMRC-213 communicates to all other DLM devices connected to the DLM Local Network. Connections shown are for example only. The low voltage LMRJ cables can connect to any DLM device with an open RJ45 receptacle.

All line voltage wiring is #12 AWG. Each relay is rated for up to 20A; total load for LMRC-213 not to exceed 20A. Specified load types can connect to any load relay. Do not connect different load types to the same relay. For dimming ballasts, connect the 0-10V control wires to the 0-10V terminals that match the load relay output connection.

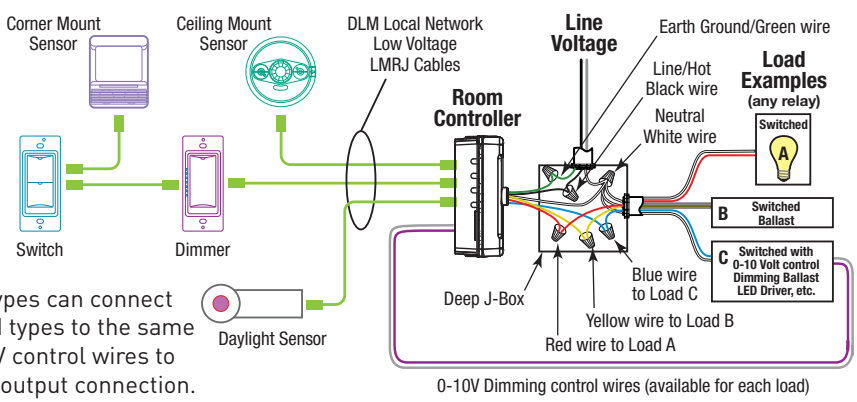

MOUNTING THE CONTROLLER

The room controller mounts as the cover for a four square deep junction box. After connecting the load and line wires, secure the LMRC-213 to the cover tabs on a deep junction box using two screws.

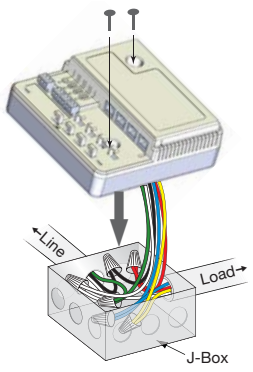

Cover a 4" x 4" x 2 1/8" deep (minimum) box

ATTACHING LMRJ LOW VOLTAGE CABLES

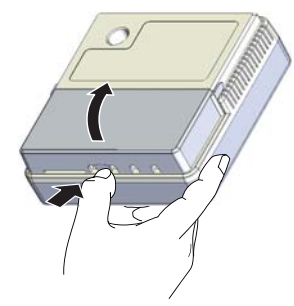

Remove rubber jack covers to use RJ45 receptacles. Leave covers in place for all unused receptacles.

0-10V CONNECTIONS

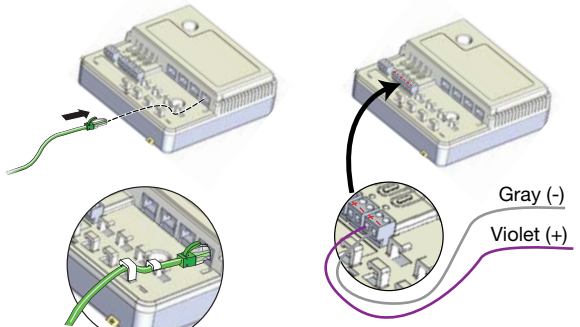

PLUG n' GO OPERATION (PnG)

Plug n' Go supports the most energy efficient control strategy. For example, if at least two loads, one switch and one occupancy sensor are connected to the DLM local network, the system operates load A as Automatic ON, Automatic OFF and load B as Manual-On, Automatic-Off.

See DLM device Quick Start Guides to determine how each device affects the PNG operation of the LMRC-213.

Load Control Arbitration

To take full advantage of automatic PnG configuration, review these simple rules about load control arbitration.

After the room controllers are connected to the DLM Local Network and powered up they automatically negotiate to determine which controller becomes the Master and the load numbers for each relay on the DLM Local Network.

The **Master** is the controller with the most load relays and the highest serial number. The LMRC-213 has three load relays.

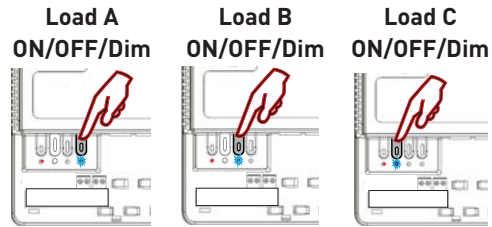

Blue LED ON when load is ON.
Load button: Press & release for ON/OFF.
Press & hold to Dim.

In a DLM local network with only LMRC-213 room controllers, the LMRC-213 with the highest serial number is the Master, carrying Load 1 and Load 2. The next highest serial number would have Load 3 and Load 4, and so forth.

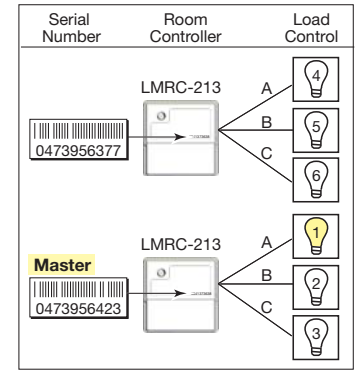

UNIT ADJUSTMENT - PUSH n' LEARN (PnL)

Load Selection Procedure

A configuration button (Config) allows access to our patented Push n' Learn™ technology to change binding relationships between sensors, switches and loads.

Step 1: Enter Push n' Learn

Press and hold the Config button (on any DLM device) for 3 seconds.

The red LED on the LMRC-213 begins to blink. When you release the button, the red LEDs on other communicating devices connected to the DLM Local Network begin to blink. They continue to blink until you exit PnL mode.

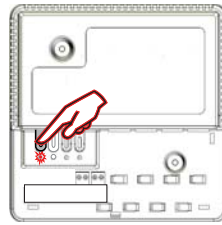

Config button & red LED

All loads in the room turn OFF immediately after entering PnL, then one load will turn ON. This is Load #1, which is bound to switch button #1 and occupancy sensors as part of the Plug n' Go factory default setting.

All switch buttons and sensors that are bound to this load have their blue LED solid ON.

Step 2: Load selection

Press and release the Config button to step through the loads connected to the DLM Local Network. As each load turns ON note the devices (switch buttons and sensors) that are showing a bright solid blue LED. These devices are currently bound to the load that is ON. The blue LED on the room controller or plug load controller connected to the load is also lit.

- To **unbind** a switch or dimmer button from a load, press the switch button while its blue LED is ON bright. The blue LED goes dim to indicate the button no longer controls the load that is currently ON.
- To **unbind** an occupancy sensor, press the up (▲) or down (▼) adjustment button while its blue LED is ON. The blue LED turns OFF to indicate the sensor no longer controls the load that is currently ON.

Pressing the switch button or sensor up (▲) or down (▼) again while the load is ON **rebinds** the load to the button or sensor and the blue LED illuminates brightly.

Step 3: Exit Push n' Learn

Press and hold the Config button until the red LED turns OFF, approximately 3 seconds.

TROUBLESHOOTING

LEDs on a switch or sensor don't light	<ol style="list-style-type: none"> 1. Check to see that the device is connected to the DLM Local Network. 2. Check for 24VDC input to the device: Plug in a different DLM device at the device location. If the device does not power up, 24VDC is not present. <ul style="list-style-type: none"> • Check the high voltage connections to the room controller and/or plug load controller(s). • If high voltage connections are good and high voltage is present, recheck DLM Local Network connections between the device and the room controller.
The wrong lights and plug loads are controlled	<ol style="list-style-type: none"> 1. Configure the switch buttons and sensors to control the desired loads using the Push n' Learn adjustment procedure.
LEDs turn ON and OFF but load doesn't switch	<ol style="list-style-type: none"> 1. Make sure the DLM local network is not in PnL. 2. Check load connections to room controllers and/or plug load controllers.
Lamps do not dim, or lamps drop out at low dim levels	<ol style="list-style-type: none"> 1. Make sure a 0-10V dimming ballast and rapid start sockets are installed per the ballast manufacturer's recommendation. Shunted sockets are typically not acceptable. 2. Check wiring per ballast manufacturer's instructions.