

ADVANCE

by  Signify

T8 LED Driver

Centium

ICN-2P16-TLED-EL-N



ICN-2P16-TLED-EL-N

Brand Name	Centium
Driver Type	T8 LED Electronic
Lamp Connection	Parallel
Input Voltage	120-277V
Input Frequency	50/60 Hz
Status	Active



Specifications

Description	Product No.	Model No.	Ordering Code	Bare Lamp Watts (W)	Nom. Initial Lumens	Min. Start Temp (°F/°C)	Num. of Lamps	Input Current (A)	Input Power (W)	Max THD%	Power Factor
Philips LED InstantFit T8 - 4' MasterClass	473974	9290020158	9.5T8/MAS/48-830/IF15/P 10/1	9.5	1500	-13/-25	2	0.21/0.09	25	10	0.99/0.95
	473982	9290020159	9.5T8/MAS/48-835/IF15/P 10/1		1500						
	473990	9290020160	9.5T8/MAS/48-840/IF16/P 10/1		1600						
	474007	9290020161	9.5T8/MAS/48-850/IF16/P 10/1		1600						
Philips LED InstantFit T8 - 4'	468694	9290013037	10T8/48-2700 IF 10/1	10	1400	-13/-25	2	0.21/0.09	25	10	0.99/0.96
	468264	9290011239C	10T8/48-3000 IF 10/1		1500						
	468272	9290011240C/D	10T8/48-3500 IF 10/1		1500						
	468280	9290011241C/D	10T8/48-4000 IF 10/1		1600						
	468298	9290011242C/D	10T8/48-5000 IF 10/1		1600						
	473966	9290013971	10T8 LED/48-2700 IF 1PK 10/1		1400						
	473974	9290013972	10T8 LED/48-3000 IF 1PK 10/1		1500						
	473982	9290013973	10T8 LED/48-3500 IF 1PK 10/1		1500						
473990	9290013974	10T8 LED/48-4000 IF 1PK 10/1	1600								
474007	9290013975	10T8 LED/48-5000 IF 1PK 10/1	1600								
Philips LED InstantFit T8 - 4' CorePro	553230	9290022527	10T8/COR/48-830/IF15/G 10/1	10	1500	-13/-25	2	0.25/0.11	29	10	0.99/0.96
	553248	9290022528	10T8/COR/48-835/IF15/G 10/1		1500						
	553214	9290019917	10T8/COR/48-840/IF16/G 10/1		1600						
553222	9290019918	10T8/COR/48-850/IF16/G 10/1	1600								
Philips LED InstantFit T8 - 4' Glass Pro	530469	9290018660	12T8/PRO/48-830/IF17/G 10/1 FB	12	1700	-13/-25	2	0.25/0.11	30	10	0.99/0.96
	530477	9290018661	12T8/PRO/48-835/IF17/G 10/1 FB		1700						
	530485	9290018662	12T8/PRO/48-840/IF18/G 10/1 FB		1800						
	530493	9290018663	12T8/PRO/48-850/IF18/G 10/1 FB		1800						
Philips LED InstantFit T8 4' High Output	473926	9290013976A	13T8/MAS/48-830/IF20/P/DIM 10/1	13	2000	-13/-25	2	0.29/0.13	34	10	0.99/0.97
	473934	9290013977A	13T8/MAS/48-835/IF20/P/DIM 10/1		2000						
	473942	9290013978B	13T8/MAS/48-840/IF21/P/DIM 10/1		2100						
	473958	9290013979A	13T8/MAS/48-850/IF21/P/DIM 10/1		2100						
	473926	9290013976	13T8/48-3000 IF 10/1		2000						
	473934	9290013977	13T8/48-3500 IF 10/1		2000						
	473942	9290013978	13T8/48-4000 IF 10/1		2100						
	473958	9290013979	13T8/48-5000 IF 10/1		2100						
Philips LED InstantFit T8 4' High Output VLC	529981	1x 9290018701 + 1x 9290013977	14T8/48-835/IF20/VLC 10/1 14T8/48-840/IF21/VLC 10/1	14	2000 2100	-13/-25	2	0.28/0.12	33	10	0.99/0.97
	529999	1x 9290018702 + 1x 9290013978									
		1x 9290018701 1x 9290018702					1	0.14/0.07	17	15	0.99/0.90

Centium ICN-2P16-TLED-EL-N

ICN-2P16-TLED-EL-N

Brand Name	Centium
Driver Type	T8 LED Electronic
Lamp Connection	Parallel
Input Voltage	120-277V
Input Frequency	50/60 Hz
Status	Active

Specifications

Description	Product No.	Model No.	Ordering Code	Bare Lamp Watts (W)	Nom. Initial Lumens	Min. Start Temp (°F/°C)	Num. of Lamps	Input Current (A)	Input Power (W)	Max THD%	Power Factor
Philips LED InstantFit T8 4' High Output Glass	470096	9290013430A	14T8/PRO/48-830/IF20/G 10/1 FB	14	2000	-13/-25	2	0.27/0.11	32	10	0.99/0.97
	470104	9290013431A	14T8/PRO/48-835/IF20/G 10/1 FB		2000						
	470112	9290013432A	14T8/PRO/48-840/IF21/G 10/1 FB		2100						
	470120	9290013433A	14T8/PRO/48-850/IF21/G 10/1 FB		2100						
	470096	9290013430	14T8 PRO LED/48-3000 IF G 10/1	14	2000	-13/-25	2	0.29/0.13	35	10	0.99/0.97
	470104	9290013431	14T8 PRO LED/48-3500 IF G 10/1		2000						
	470112	9290013432	14T8 PRO LED/48-4000 IF G 10/1		2100						
	470120	9290013433	14T8 PRO LED/48-5000 IF G 10/1		2100						
Philips LED InstantFit T8 4' Ultra High Output	545178	9290020162	15.5T8/MAS/48-830/IF23/P 10/1	15.5	2300	-13/-25	2	0.26/0.12	31	10	0.99/0.96
	533372	9290020163	15.5T8/MAS/48-835/IF24/P 10/1		2400						
	545194	9290020164	15.5T8/MAS/48-840/IF25/P 10/1	15.5	2500	-13/-25	1	0.16/0.08	20	15	0.99/0.92
	545200	9290020165	15.5T8/MAS/48-850/IF25/P 10/1		2500						
	468892	9290013044	16.5T8 LED/48-3000 IF 10/1 UHO	16.5	2300	-13/-25	2	0.30/0.13	35	10	0.99/0.97
	463133	9290012267	16.5T8 LED/48-3500 IF 10/1 UHO		2400						
463141	9290012268	16.5T8 LED/48-4000 IF 10/1 UHO	2500								
463158	9290012269	16.5T8 LED/48-5000 IF 10/1 UHO	2500								
Philips LED InstantFit T8 - 3'	539858	9290019675	8.5T8/MAS/36-830/IF13/P 10/1	8.5	1300	-13/-25	2	0.17/0.08	21	10	0.99/0.93
	539866	9290019679	8.5T8/MAS/36-835/IF13/P 10/1		1300						
	539874	9290019676	8.5T8/MAS/36-840/IF14/P 10/1	8.5	1400	-13/-25	1	0.09/0.05	11	15	0.97/0.82
	539882	9290019677	8.5T8/MAS/36-850/IF14/P 10/1		1400						
	469320	9290013113	9T8 LED/36-3000 IF 10/1	9	1100	-13/-25	2	0.16/0.07	19	10	0.99/0.92
	469338	9290013114	9T8 LED/36-3500 IF 10/1		1100						
469346	9290013115	9T8 LED/36-4000 IF 10/1	1200								
469353	9290013116	9T8 LED/36-5000 IF 10/1	1200								
Philips LED InstantFit T8 - 2'	541813	9290019869	7T8/MAS/24-830/IF10/P 10/1	7	1050	-13/-25	2	0.15/0.07	18	10	0.99/0.92
	541821	9290019870	7T8/MAS/24-835/IF10/P 10/1		1050						
	541839	9290019871	7T8/MAS/24-840/IF11/P 10/1		1150						
	541847	9290019872	7T8/MAS/24-850/IF11/P 10/1		1150						
	469270	9290013108	7T8 LED/24-3000 IF 10/1	7	1050	-13/-25	1	0.08/0.04	10	15	0.98/0.82
	469288	9290013109	7T8 LED/24-3500 IF 10/1		1050						
	469296	9290013110	7T8 LED/24-4000 IF 10/1		1150						
469304	9290013111	7T8 LED/24-5000 IF 10/1	1150								
Philips LED InstantFit U-Bent T8 - 6U	541854	9290019874	13T8-6U/MAS/24-830/IF20/P 10/1	13	2000	-13/-25	2	0.30-0.17	35	10	0.99/0.97
	541862	9290019875	13T8-6U/MAS/24-835/IF20/P 10/1		2000						
	541870	9290019876	13T8-6U/MAS/24-840/IF21/P 10/1	13	2100	-13/-25	1	0.14-0.07	17	15	0.98/0.90
	541888	9290019877	13T8-6U/MAS/24-850/IF21/P 10/1		2100						
	469379	9290013118	13T8 LED/24-3000 IF-6U 10/1	13	2000	-13/-25	2	0.21/0.09	25	10	0.99/0.97
	469387	9290013119	13T8 LED/24-3500 IF-6U 10/1		2000						
	469395	9290013120	13T8 LED/24-4000 IF-6U 10/1		2100						
	469403	9290013121	13T8 LED/24-5000 IF-6U 10/1		2100						

Centium ICN-2P16-TLED-EL-N

ICN-2P16-TLED-EL-N

Brand Name	Centium
Driver Type	T8 LED Electronic
Lamp Connection	Parallel
Input Voltage	120-277V
Input Frequency	50/60 Hz
Status	Active

Enclosure

	In. (cm)
Case Width (W)	1.3 (3.3)
Case Height (H)	1.0 (2.5)
Mounting Length (M)	8.90 (22.6)
Overall Length (L1)	9.5 (24.1)

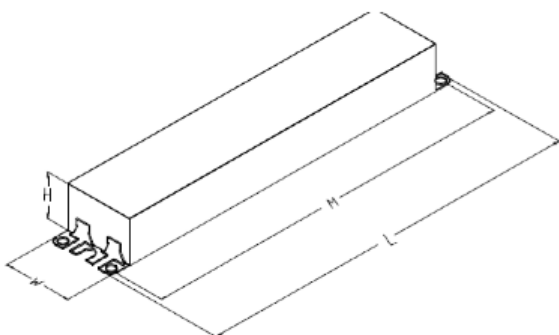

Wiring Diagram

	In. (cm)
Black	24 (61)
White	24 (61)
Blue	28 (71.1)
Red	43 (109.2)

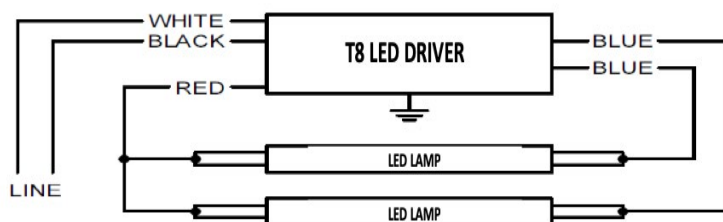

Centium ICN-2P16-TLED-EL-N

ICN-2P16-TLED-EL-N

Brand Name	Centium
Driver Type	T8 LED Electronic
Lamp Connection	Parallel
Input Voltage	120-277V
Input Frequency	50/60 Hz
Status	Active

Electrical Specifications

Section I - Physical Characteristics

- 1.1 Driver shall be physically interchangeable with standard electromagnetic or standard electronic ballasts, where applicable.
- 1.2 Driver shall be provided with integral leads color coded per ANSI C82.11.

Section II - Performance Requirements

- 2.1 Driver shall energize compatible LED lamps within 1 second after mains power is applied.
- 2.2 Driver shall provide Independent Lamp Operation (ILO) allowing remaining lamp(s) to maintain full light output when one or more lamps fail.
- 2.3 Driver shall contain auto restart circuitry in order to restart lamps without resetting power.
- 2.4 Driver shall operate from a 50Hz or 60 Hz AC input source of 120V through 277V with sustained variations of +/- 10% (voltage and frequency).
- 2.5 Driver shall be high frequency electronic type and operate lamps at frequencies above 42 kHz to avoid interference with infrared devices and eliminate visible flicker.
- 2.6 Driver shall have a Power Factor of 0.90 or above when operating the maximum rated number of compatible lamps, and 0.88 or above when operating the minimum rated number of compatible lamps.
- 2.7 Driver input current shall Total Harmonic Distortion (THD) of 10% or less when operating the maximum rated number of compatible lamps and 15% or less when operating the minimum rated number of compatible lamps.
- 2.8 Driver shall have a Class A sound rating.
- 2.9 Driver shall have a minimum starting temperature of -13°F / -25°C.
- 2.10 Driver shall tolerate sustained open circuit and short circuit output conditions.
- 2.11 Driver shall be capable of operating lamps remotely and in tandem for wire lengths up to 20 ft.
- 2.12 Driver shall be suitable of operation in up to a 45°C ambient temperature.

Section III - Regulatory Requirements

- 3.1 Driver shall not contain any Polychlorinated Biphenyl (PCB).
- 3.2 Driver shall be Underwriters Laboratories (UL) Recognized, and suitable for Damp and Dry conditions; and CSA Certified where applicable.
- 3.3 Driver shall comply with ANSI C62.41 Category A Transient protection.
- 3.4 Driver shall comply with the requirements of the Federal Communication Commission (FCC) rules and regulations, Title 47, CFR part 15, Non-Consumer (Class A) for EMI/RFI (conducted and radiated).
- 3.5 Driver shall comply with NEMA 410 for in-rush current limits.

Section IV - Other

- 4.1 Driver shall be manufactured in a factory certified to ISO 9001 Quality System Standards.
- 4.2 Driver shall carry a five year warranty from date of manufacture against defects in material and workmanship when operating in a 45°C ambient environment or less.

The information presented in this document is not intended as any commercial offer and does not form part of any quotation or contract.

