

REVISIONS			
REV	DESCRIPTION	DATE	APPROVED

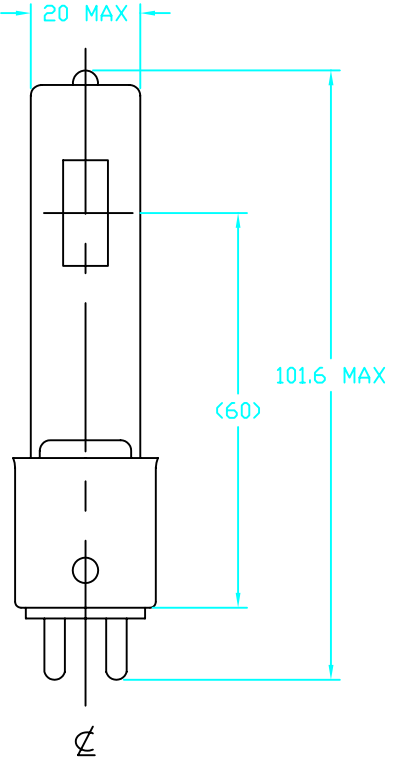

NOTES:

1. ALL DIMENSIONS ARE IN MM.
2. SEAL TEMP: SHOULD BE MAINTAINED BELOW 350°C
3. THE DIMENSIONS AND SPECIFICATIONS OF PRODUCT LISTED IN THIS SHEET ARE SUBJECT TO CHANGE WITHOUT NOTICE FOR IMPROVEMENT.

CHARACTERISTICS	
VOLTAGE	115 V
WATTAGE	600 W
TOTAL LUMEN	15600 Lm
COLOR TEMP.	3200 K
BASE TYPE	G9.5
AVERAGE LIFE	300 HRS
FILAMENT TYPE	C-13D
BURN POSITION	ANY

ITEM	QTY	DESCRIPTION	CODE IDENT	PART NUMBER	REMARKS
LIST OF MATERIALS					
UNLESS OTHERWISE SPECIFIED DIMENSIONS ARE IN INCHES		CONTRACT NO.		USHIO AMERICA, INC. 5440 Cerritos Avenue Cypress, CA 90630	
DECIMALS .X ± -		APPROVALS			
.XX ± -		DATE		TITLE GLC/HP-600 JCS115V-600WCM	
.XXX ± -		DRAWN G.LASKOWSKI 1/8/97			
ANGLES ± -		CHKD D.GILCZYNSKI 1/8/97			
DRILLED HOLES PER AND 10387 REMOVE BURRS AND SHARP EDGES ALL DIMENSIONS AFTER PLATING		ENGR			
MATERIAL		MFG		SIZE	
COMPOSITE		QUAL		CODE IDENT NO.	
FINISH		DSGN ACTVY		DWG NO.	
APPLICATION		GOVT ACTVY		B GLC 1000665	
				SCALE NONE WEIGHT SHEET 1 OF 1	

