

| | | | | | |
|-------------|--|-----------|--|------|--|
| Project | | Catalog # | | Type | |
| Prepared by | | Notes | | Date | |



WaveLinx

DALI Digital to Analog Converter (DAC-DC1 / DAC-DC2)

Lighting control device used to control any standard 0-10V current sourcing dimmable ballast/driver

Typical Applications

Office • Education • Healthcare • Hospitality • Retail • Industrial • Manufacturing

Interactive Menu

- Ordering Information [page 2](#)
- Additional Resources [page 3](#)
- Wiring Diagrams [page 3](#)
- Connected Systems [page 5](#)
- Product Warranty



Product Features



Compatibility



Overview

The Digital to Analog Converter (DAC) is a lighting control device used to control any standard 0-10V current sourcing dimmable ballast/driver. It allows dimming control by sending 0-10V dimming and on/off commands to the DAC via the WaveLinx DALI Bus.

Product Features & Benefits

- Built-in latching relay and 0-10V current sinking interface
- All DAC's device settings configured through the software
- Automatic detection of WaveLinx DALI Local Bus loss of power for Emergency lighting control (UL924)
- Available for Class 1 or Class 2 wiring configurations
- Ultra-low profile form factor designed
- Options to meet Buy American Act requirements

[additional product diagrams](#)

Order Information

Catalog Number

| Domestic Preferences ⁽¹⁾ | Catalog Number | Description |
|---|----------------|---|
| [Blank] =Standard BAA = Buy American Act | DAC-DC1 | Digital to Analog Converter - wiring exits with line voltage wiring for Class 1 installations of the two wire communications bus. |
| [Blank] =Standard BAA = Buy American Act | DAC-DC2 | Digital to Analog Converter - wiring exits with line voltage wiring for Class 2 installations of the two wire communications bus. |

Notes

(1) Only product configurations with this designated prefix are built to be compliant with the Buy American Act of 1933 (BAA). Please refer to [DOMESTIC PREFERENCES](#) website for more information. Components shipped separately may be separately analyzed under domestic preference requirements.

Product Specifications

Key Features

- Built-in latching relay and 0-10V current sinking interface used to integrate individual or a group of dimmable 0-10V ballasts/drivers
- All DAC's device settings (fade, scenes and groups) configured through the software, eliminating the need for manual adjustments
- Automatic detection of the WaveLinx DALI Bus power loss with default to closed and full bright (100% lighting)
- Available for Class 1 or Class 2 wiring configurations
- Ultra low profile form factor designed to fit inside driver/ballast compartment of most standard luminaires
- Easily mountable to fixture housing through standard knockout using supplied 90° elbow and mounting clip
- Powered by the WaveLinx DALI Bus. Line in and load out connection to driver/ballast, neutral & ground connection are not required.

Standards/Ratings

- UL 924, Emergency Lighting and Power Equipment
- UL 916, Energy Management Equipment
- CSA C22.2 No. 141-10, Emergency Lighting Equipment
- CSA C22.2 No.205, Signal Equipment
- Manufactured in an ISO 9001 certified factory
- Meets ASHRAE Standard 90.1 requirements
- Meets IECC 2015 requirements
- Meets CEC Title 24 requirements

Warranty

Five year warranty standard

Mechanical

Dimensions: 1"H x 3.94"W x 1.125"L (25.4mm x 100mm x 28.6mm)

Mounting:

- In fixture or junction box mounting only.
Refer to Wiring Diagram section of spec sheet for proper wiring details.

Environment:

- **Temperature:** 32°F to 140°F (0°C to 60°C)
- **Relative Humidity:** 10% to 90% (non-condensing). For indoor use only.

Electrical

Relay Output:

- **Input Voltage:** 120-347 VAC (+/- 10%) 50/60Hz (Single Phase)
- **Maximum Ballast/General Load for operating temperature lower than 104F:** 4.5A @ 120-347 VAC
- **Maximum Ballast/General Load for operating temperature higher than 104F:** 3A @ 120-347 VAC
- **Maximum Tungsten Load:** 8A @ 120 VAC, 5.8A @ 240 VAC
- **Input Frequency:** 50/60 Hz

Control Specification:

- **Communication Interface:** WaveLinx DALI Bus (topology, polarity free)
- **Current Draw:** 3.75mA
- **Analog Dimming Current Draw:** 0-10 VDC, 50mA max current sink only
Note: Upon first power up allow 4-6 seconds before sending commands

Wiring:

- **Relay:** 18 AWG solid TFN non-polarized pair
- **0-10V Dimming:** 18 AWG solid TFN polarized pair
- **Communication:** 18 AWG stranded PTGE plenum rated non-polarized pair

Dimensional Details

Side View

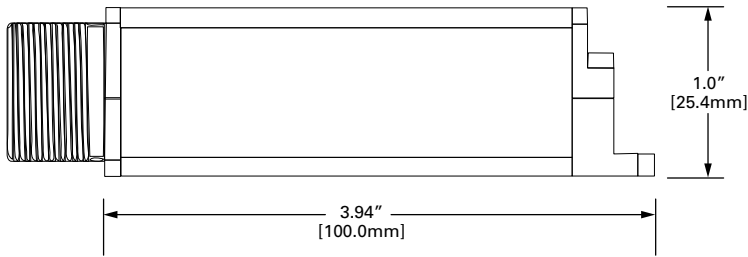

Angled View

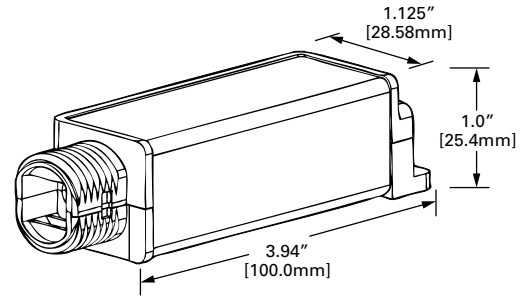

Wiring Diagram

DAC-DC1 and DAC-DC2

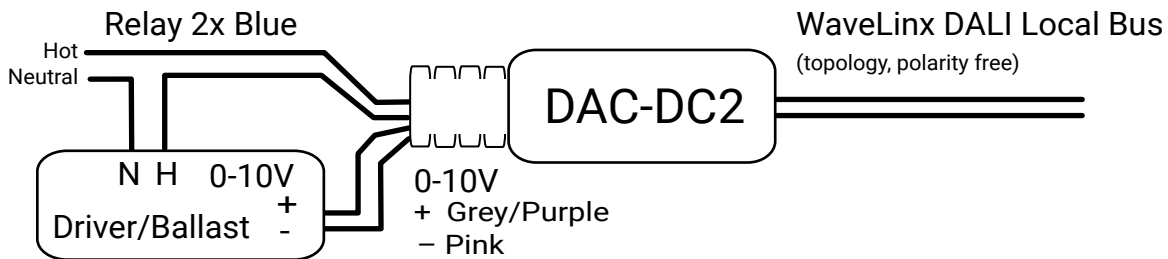
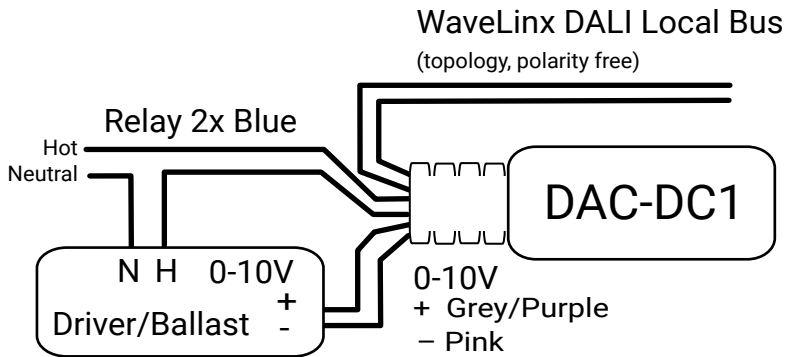

Note: Install in accordance with all applicable National and local electrical and building codes.

Note: Specifications subject to change without notice.

Note: Older models DAC-DC1/DC2 have 0-10V wiring, +Grey/Purple and -Grey.

System Diagram:

This diagram shows the the main components and topology of the WaveLinx system with DALI devices. The WaveLinx DALI devices use DALI-2 wires for device to device communications while connected to a WaveLinx Area Controller. The WaveLinx DALI enables DALI certified luminaries/drivers and peripherals to function with other WaveLinx devices.

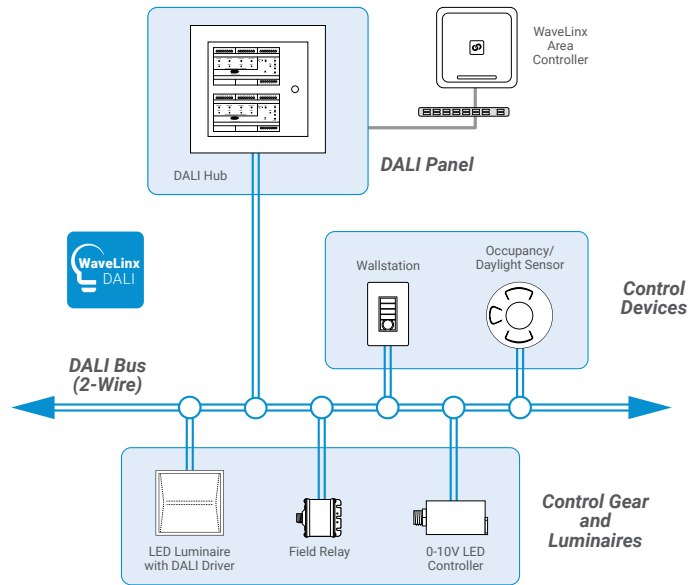

System Diagram:

This diagram shows the main components of the WaveLinx connected lighting system with WaveLinx DALI, CAT and PRO devices.

The PRO devices communicate using wireless mesh technology based on the IEEE 802.15.4 standard. A PoE LAN connection for each WaveLinx Area Controller (WAC) is required for power and data access to the building lighting network.

The CAT devices communicate over the category 5 based communication bus and control the light fixtures using a relay (on/off) and 0-10V output (dim/raise).

WaveLinx DALI devices communicate via a DALI bus (2 wires), which connects various components including DALI fixtures, a DALI DAC (DALI to 0-10V converter), DALI field relays, DALI wallstations, and DALI occupancy sensors.

WaveLinx Area Controllers (WAC) communicate with WaveLinx CORE Apps over the Ethernet network.

[View WaveLinx Network and IT Guidance Technical Guide](#)

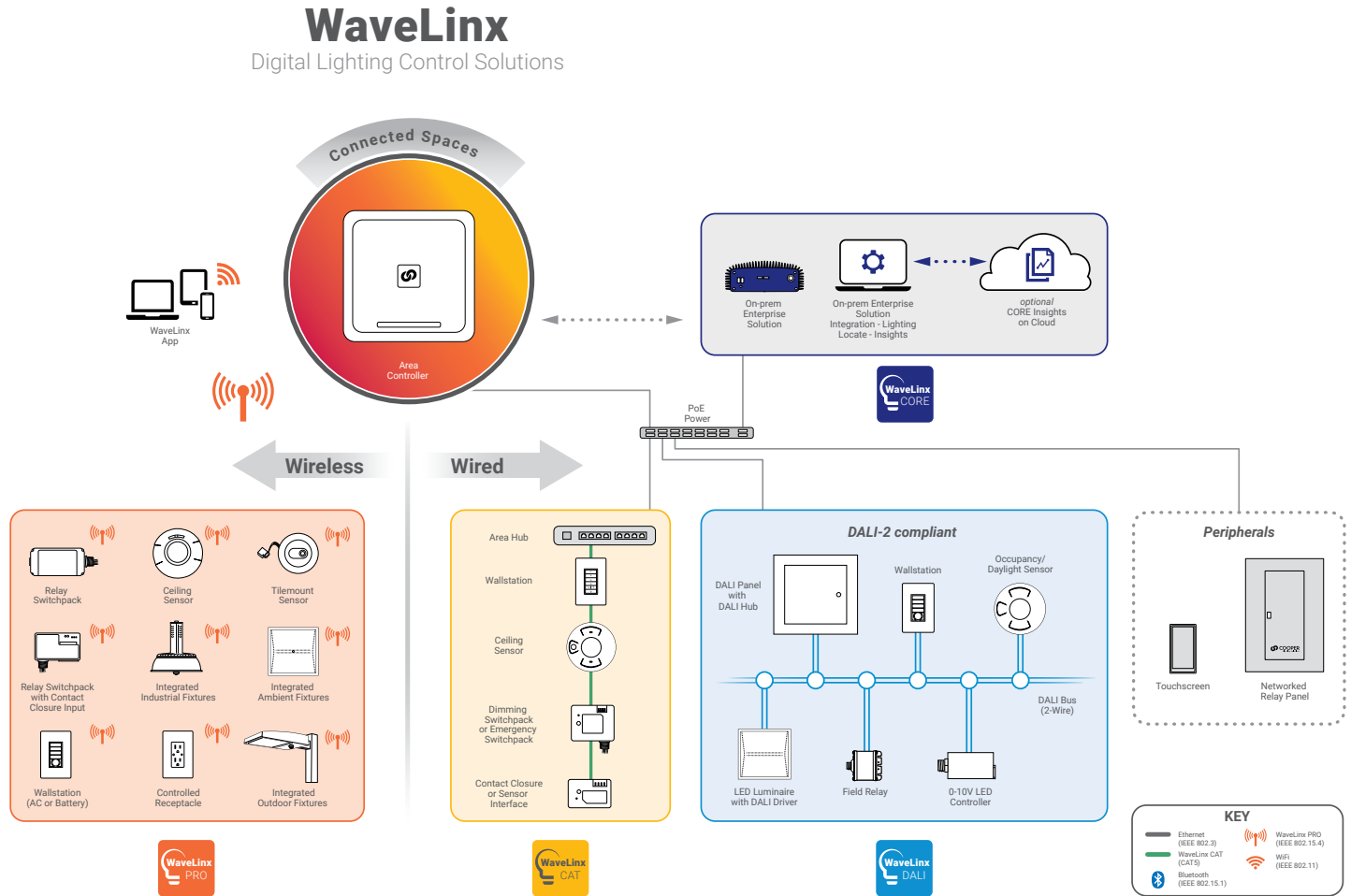

Control Systems
• WaveLinx