



## AFLEX Linear Specification Sheet

Programmable Constant Current  
0-10V Dimmable LED Driver

### Key Features

- Dim-To-Dark, 0.1% minimum with 0-10V controls; digital controls not required
- Fast "tap and go" wireless NFC programming
- Optional programmable power for critical energy calculations
- Meets CA Title 24 / JA8 requirements

### Specification Overview

- 0-10V dimming with dim-to-off (programmable)
- Universal input voltage 120 to 277VAC
- Programmable from 100-2000mA (1mA steps)
- Operating voltage range from 10VDC to 57VDC
- UL8750, Class 2, Class P
- 12V or 24V auxiliary power output (optional)

### FlexTool

#### Fast, easy wireless programming

With FlexTool, customers can quickly and easily configure multiple parameters of the driver in the shop or in the field. Our programming is one of the easiest in the industry and can be done in less than one second.

FlexTool provides quick, accurate wireless programming on the production floor, in the electrical shop or in the field:

- No complicated 2-wire programming jigs or probes
- Quick "tap and go" process, less than 0.1 seconds
- Audible "beep" confirms programming
- Driver can be programmed without powering up driver



FlexTool laptop-based software configures multiple parameters:

- Input Power in Watts
- Output Current in mA
- Dimming Curve
- Dim-to-Off Functionality
- NTC Settings and More

120-277V

CLASS 2

CLASS P



IP40



### Enclosure Details

Dimensions	Material	Finish	Environmental
12.0" W x 1.2" H x 1.0" D (305mm x 30.5mm x 25.4mm)	Aluminum	Anodized	IP40

### ORDERING INFORMATION

#### Stock Models for Programming in the Field

Part Number	Description
AFLEX-100W-1650-L-LE	AFLEX Linear, 120-277, 100W, 10-57VDC, 1650mA, Linear Dim, 12V Aux (57V Output)
AFLEX-100W-2000-L-LB	AFLEX Linear, 120-277, 100W, 10-50VDC, 2000mA, Linear Dim, 12V Aux (50V Output)

#### 1650mA/57VDC Max

Drivers programmed at factory with standard 100W maximum output.

**Use for driver field replacements (meets Class P requirements).**

Model	Wattage	Current	Case Style	Dim Curve	Aux Out
<b>AFLEX</b>			<b>L</b>		
AFLEX   AFLEX	<b>100W</b>   100 Watt Max	<b>0100</b>   100mA Min	L   Linear	<b>G</b>   Logarithmic	<b>E</b>   12V Aux (10-57VDC)
	<b>(10-57VDC)</b>	Up To		<b>L</b>   Linear	<b>F</b>   24V Aux (10-57VDC)
		<b>1650</b>   1650mA Max			<b>G</b>   No Aux (10-57VDC)

#### 2000mA/50VDC Max

Drivers programmed at factory with standard 100W maximum output.

**Use for driver field replacements (meets Class P requirements).**

Model	Wattage	Current	Case Style	Dim Curve	Aux Out
<b>AFLEX</b>			<b>L</b>		
AFLEX   AFLEX	<b>100W</b>   100 Watt Max	<b>0100</b>   100mA Min	L   Linear	<b>G</b>   Logarithmic	<b>B</b>   12V Aux (10-50VDC)
	<b>(10-50VDC)</b>	Up To		<b>L</b>   Linear	<b>C</b>   24V Aux (10-50VDC)
		<b>2000</b>   2000mA Max			<b>D</b>   No Aux (10-50VDC)

#### Custom Models Programmed at Factory if Maximum Rated Power Required is Less Than 100W

Note: Generally not required for replacement drivers. Beneficial for OEMs requiring lower max wattage to meet energy calculations.

Model	Wattage <sup>1</sup>	Current <sup>2</sup>	Case Style	Dim Curve	Aux Out
<b>AFLEX</b>	<b>75W</b>				
AFLEX   AFLEX	<b>75W</b>   75 Watt	<b>0100</b>   100mA Min	L   Linear	<b>G</b>   Logarithmic	<b>B</b>   12V Aux (10-50VDC)
	<b>10-50VDC</b>	Up To		<b>L</b>   Linear	<b>C</b>   24V Aux (10-50VDC)
		<b>1500</b>   1500mA Max			<b>D</b>   No Aux (10-50VDC)
<b>AFLEX</b>	<b>60W</b>				
AFLEX   AFLEX	<b>60W</b>   60 Watt	<b>0100</b>   100mA Min	L   Linear	<b>G</b>   Logarithmic	<b>B</b>   12V Aux (10-50VDC)
	<b>10-50VDC</b>	Up To		<b>L</b>   Linear	<b>C</b>   24V Aux (10-50VDC)
		<b>1200</b>   1200mA Max			<b>D</b>   No Aux (10-50VDC)
<b>AFLEX</b>	<b>40W</b>				
AFLEX   AFLEX	<b>40W</b>   40 Watt	<b>0100</b>   100mA Min	L   Linear	<b>G</b>   Logarithmic	<b>B</b>   12V Aux (10-50VDC)
	<b>10-50VDC</b>	Up To		<b>L</b>   Linear	<b>C</b>   24V Aux (10-50VDC)
		<b>800</b>   800mA Max			<b>D</b>   No Aux (10-50VDC)

<sup>1</sup> Driver can be programmed for maximum power in 1W increments up to 100W – consult factory for further details.

<sup>2</sup> Driver can operate with LED loads up to 57V at lower maximum driver currents – consult factory for further details.

### SPECIFICATIONS

— 1650mA Max Version —

#### Input

Input Voltage Range	120 to 277VAC ± 10%
Input Frequency	50/60Hz
Input Current	0.8A @ 120VAC 0.4A @ 277VAC*
Inrush Current	38A Max
Efficiency	> 88%*
Power Factor	0.99 @ 120VAC 0.97 @ 277VAC

\*Depending on model

#### Output

Output Voltage Range	10 to 57VDC*
Output Current Range	100 to 1650mA* (1mA Step Programmable)
Output Current Tolerance	< 5%
Output Current Ripple	< 5% @ Max load
Line Regulation	+/- 5%
Load Regulation	+/- 5%
Turn-On Delay Time	0.4 sec @ Max load
Sensor Power Supply (Aux)	12 or 24V up to 160mA (Programmable)*
Stand-By Power	> 1W

\*Depending on model

#### Environmental

Env. Protection Rating	IP40
Surge Protection	2.5kV
Operating Ambient Temp.	-40°C to +60°C
Operating Temperature	-40°C to +50°C
Storage Temperature	-40°C to +85°C
Expected Lifetime	50k hours at 75°C
Audible Noise	< 24dB Class A
Withstanding Voltage	2.5kV

#### Dimming

Dimming Control	0 to 10V
Dimming Input Range	-2 to +15V
Dimming Curves	Linear/Logarithmic (Programmable)
Min. Dimming Level	Dim down to 0.1%
Dim-to-Off	Yes (Programmable)
Current Consumption	0.35mA / Source
Compliance	0-10V Dimming Compliance with ANSI C137.1

#### LED Thermal Protection (NTC)

NTC Value	15 kΩ ± 5% @ 25°C
Manufacture: Vishay	P/N: NTCS0805E3153JMT
Output Level Range	1mA Step Programmable (0 to 100%)

#### Protection

Over Current Protection	Yes; Current Limiting
Short Circuit Protection	Yes; Hiccup Mode
Over Voltage Protection	Yes; Hiccup Mode
Over Temp. Protection	Yes; Power Derating
Mis-Wiring Protection	Yes; Auto Shutdown

#### Mechanical Housing

Length	12.00" (304.8mm)
Mounting Length	11.70" (296.8mm)
Width	1.20" (30.48mm)
Height	1.00" (25.4mm)
Housing Material	Aluminum
Housing Color	Blue Anodized
Junction Box	No
Input Connector Types	Black & White Wago 253, Dual Side 16 to 20AWG strip 3/8"
Output Connector Types	Red & Blue Wago 253, Dual Side 16 to 20AWG strip 3/8"
Dimming Connector Types	Purple & Gray Wago 253, Dual Side 16 to 20AWG strip 3/8"
Auxiliary Connector Types	Yellow & Gray Wago 253, Dual Side 16 to 20AWG strip 3/8"
NTC Connector Types	Orange & Orange Wago 253, Dual Side 16 to 20AWG strip 3/8"
Mounting	2 half-hole flange mounts

#### Approval Markings

Certificates / Approval Signs	UL 8750, Class 2, Class P
-------------------------------	---------------------------

### SPECIFICATIONS

— 2000mA Max Version —

#### Input

Input Voltage Range	120 to 277VAC ± 10%
Input Frequency	50/60Hz
Input Current	0.8A @ 120VAC 0.4A @ 277VAC*
Inrush Current	38A Max
Efficiency	> 88%*
Power Factor	0.99 @ 120VAC 0.97 @ 277VAC

\*Depending on model

#### Output

Output Voltage Range	10 to 50VDC*
Output Current Range	100 to 2000mA* (1mA Step Programmable)
Output Current Tolerance	< 5%
Output Current Ripple	< 5% @ Max load
Line Regulation	+/- 5%
Load Regulation	+/- 5%
Turn-On Delay Time	0.4 sec @ Max load
Sensor Power Supply (Aux)	12 or 24V up to 160mA (Programmable)*
Stand-By Power	> 1W

\*Depending on model

#### Environmental

Env. Protection Rating	IP40
Surge Protection	2.5kV
Operating Ambient Temp.	-40°C to +60°C
Operating Temperature	-40°C to +75°C
Storage Temperature	-40°C to +85°C
Expected Lifetime	50k hours at 75°C
Audible Noise	< 24dB Class A
Withstanding Voltage	2.5kV

#### Dimming

Dimming Control	0 to 10V
Dimming Input Range	-2 to +15V
Dimming Curves	Linear/Logarithmic (Programmable)
Min. Dimming Level	Dim down to 0.1%
Dim-to-Off	Yes (Programmable)
Current Consumption	0.35mA / Source
Compliance	0-10V Dimming Compliance with ANSI C137.1

#### LED Thermal Protection (NTC)

NTC Value	15 kΩ ± 5% @ 25°C
Manufacture: Vishay	P/N: NTCS0805E3153JMT
Output Level Range	1mA Step Programmable (0 to 100%)

#### Protection

Over Current Protection	Yes; Current Limiting
Short Circuit Protection	Yes; Hiccup Mode
Over Voltage Protection	Yes; Hiccup Mode
Over Temp. Protection	Yes; Power Derating (Refer to graph on page 7)
Mis-Wiring Protection	Yes; Auto Shutdown

#### Mechanical Housing

Length	12.00" (304.8mm)
Mounting Length	11.70" (296.8mm)
Width	1.20" (30.48mm)
Height	1.00" (25.4mm)
Housing Material	Aluminum
Housing Color	Blue Anodized
Junction Box	No
Input Connector Types	Black & White Wago 253, Dual Side 16 to 20AWG strip 3/8"
Output Connector Types	Red & Blue Wago 253, Dual Side 16 to 20AWG strip 3/8"
Dimming Connector Types	Purple & Gray Wago 253, Dual Side 16 to 20AWG strip 3/8"
Auxiliary Connector Types	Yellow & Gray Wago 253, Dual Side 16 to 20AWG strip 3/8"
NTC Connector Types	Orange & Orange Wago 253, Dual Side 16 to 20AWG strip 3/8"

Mounting 2 half-hole flange mounts

#### Approval Markings

Certificates / Approval Signs UL 8750, Class 2, Class P

**MECHANICAL DIAGRAMS**

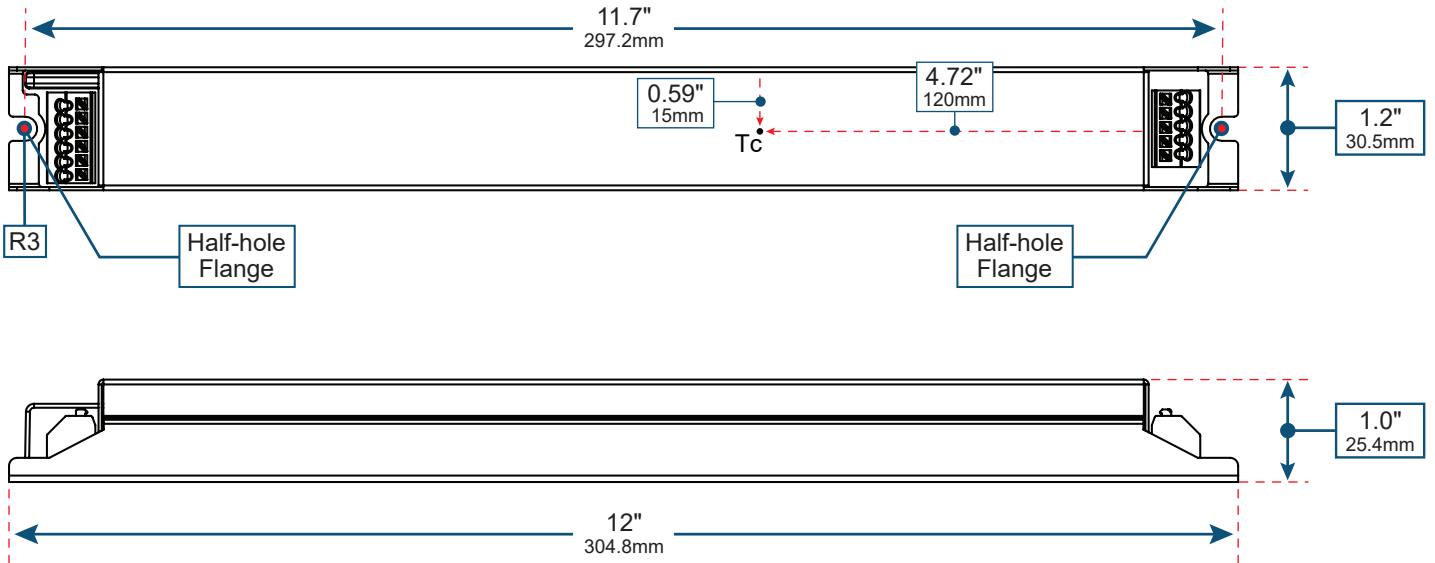

**OPERATING POWER OUTPUT**

— 1650mA Max Version —

— 2000mA Max Version —

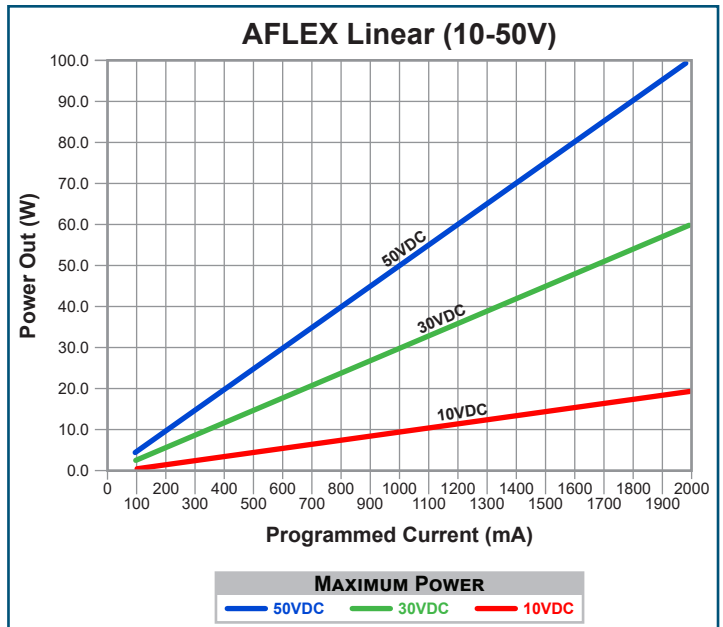
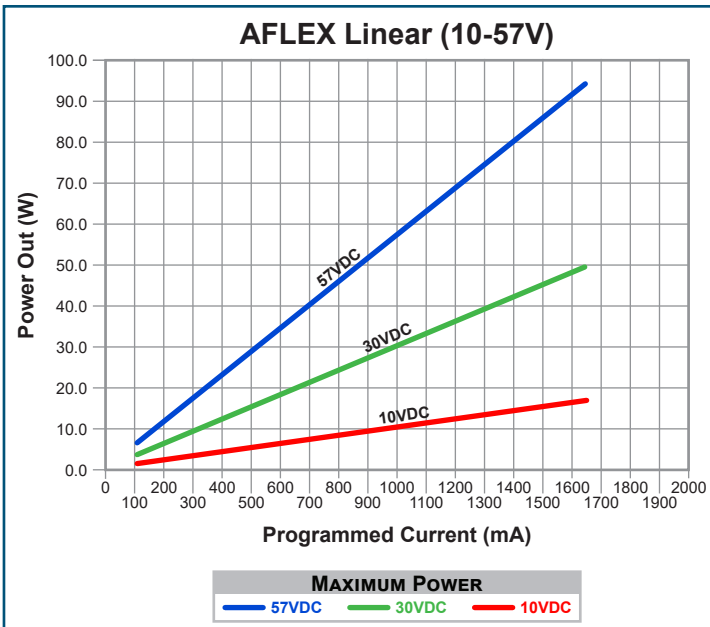

**PERFORMANCE SPECIFICATIONS**

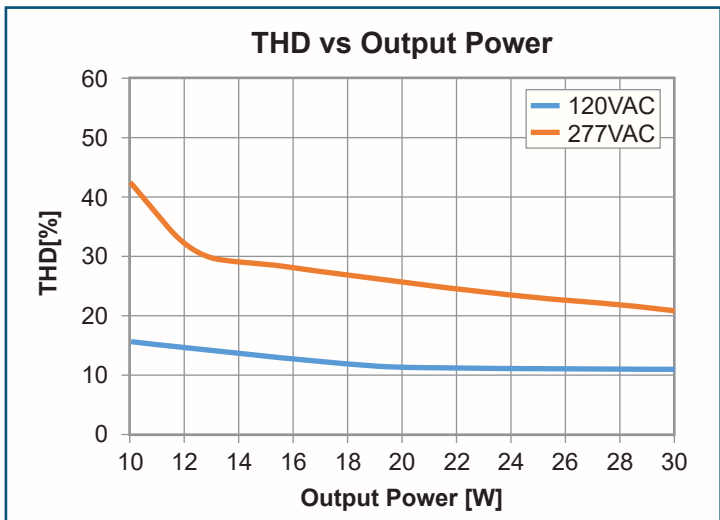
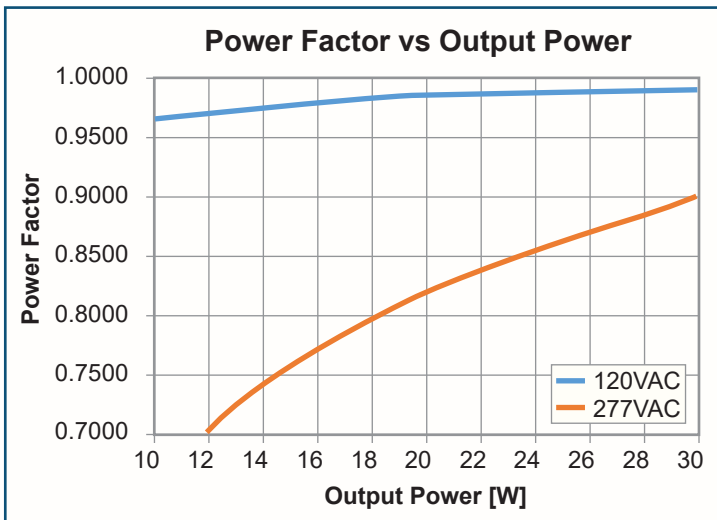
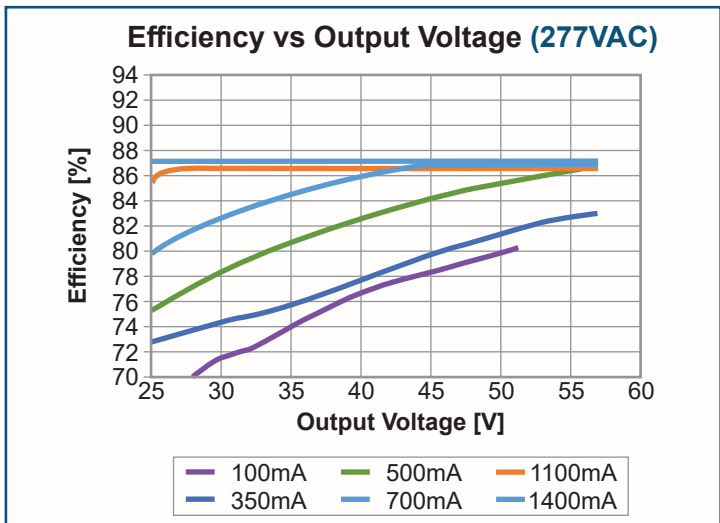
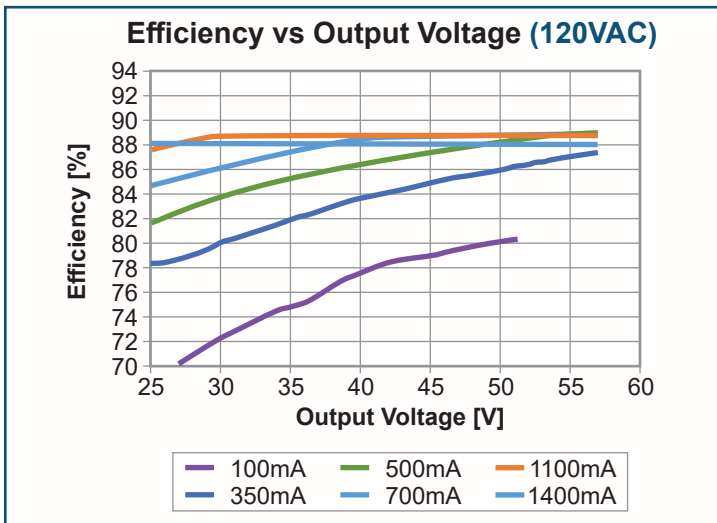
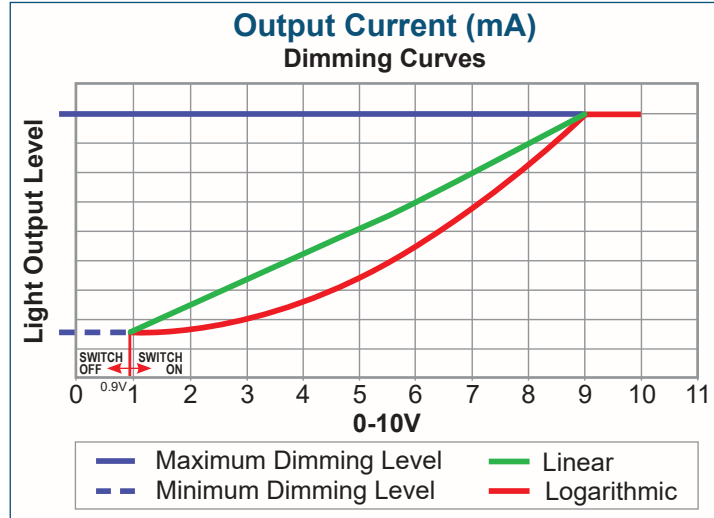

**THE IEEE P1789 FLICKER TEST PERFORMANCE RESULTS**

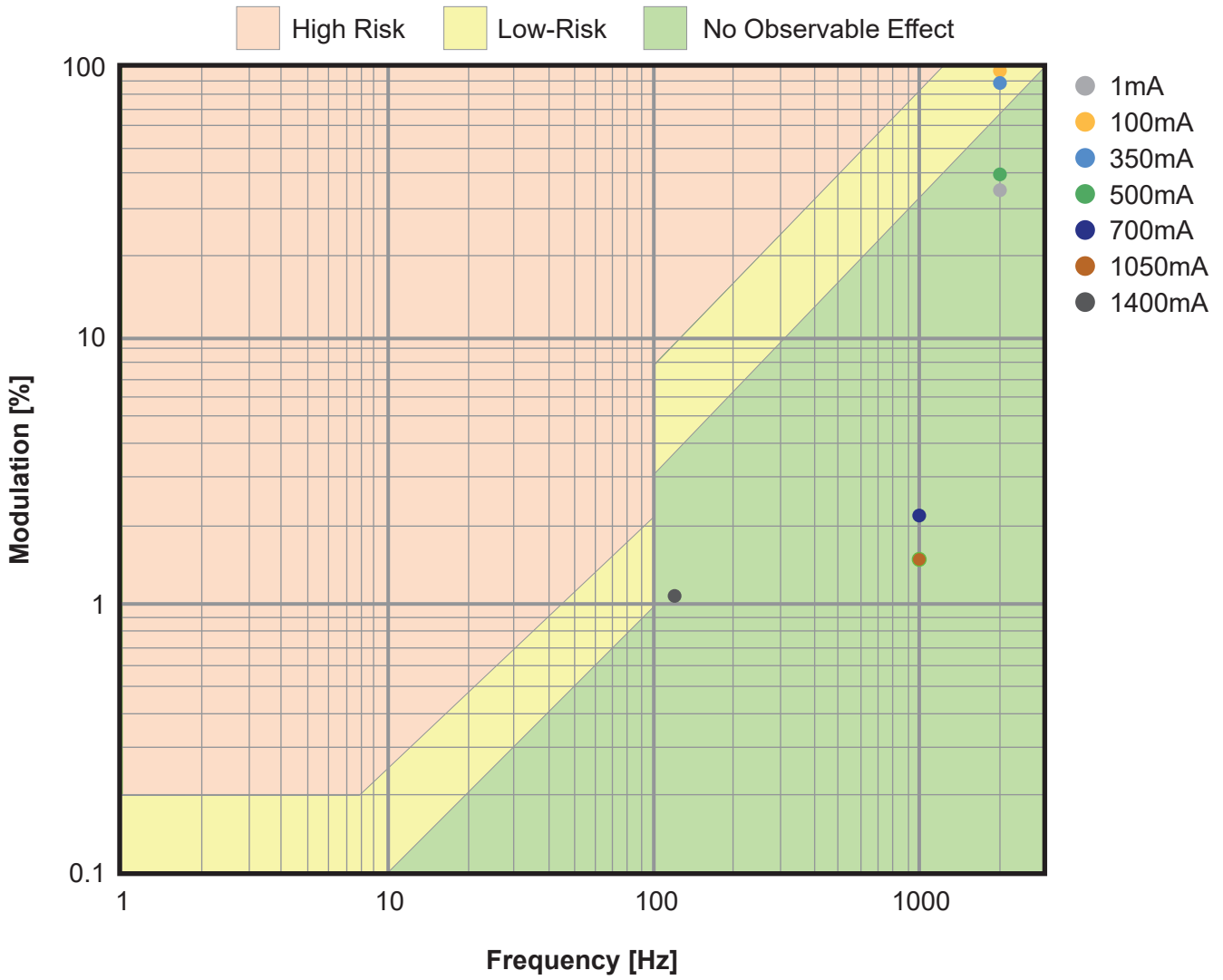

**LED THERMAL PROTECTION (NTC)**

AFLEX Series drivers help protect the LED's lifetime and will reduce LED temperature by derating the output current in case of high temperatures. The negative temperature coefficient (NTC) thermistor must be connected to the LED driver, as shown in the wiring diagram.

For maximum performance, the NTC thermistor must be placed close to the Tc point of the LED module. The power derating parameters can be programmed using the FlexTool programmer. The NTC outputs can be left disconnected if thermal protection is not required.

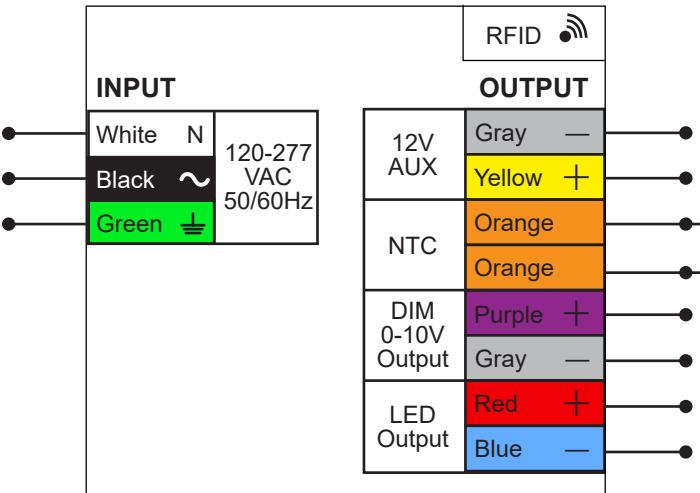

Compatible NTC Thermistor*		
Specification	Manufacturer	Manufacturer P/N
15 kΩ ± 5% @ 25°C	Vishay	NTCS0805E3153JMT

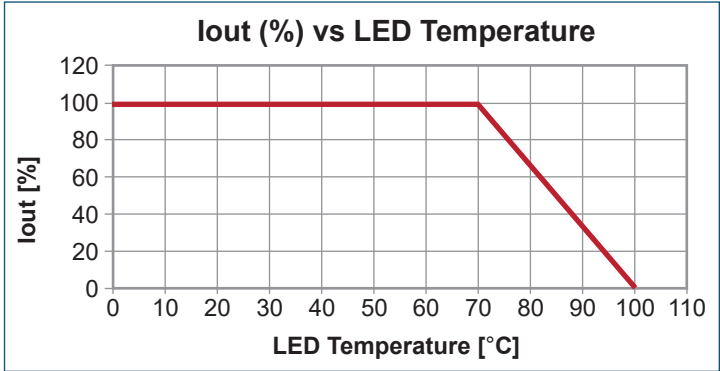
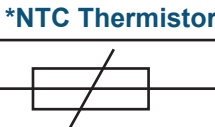

**DRIVER THERMAL PROTECTION**

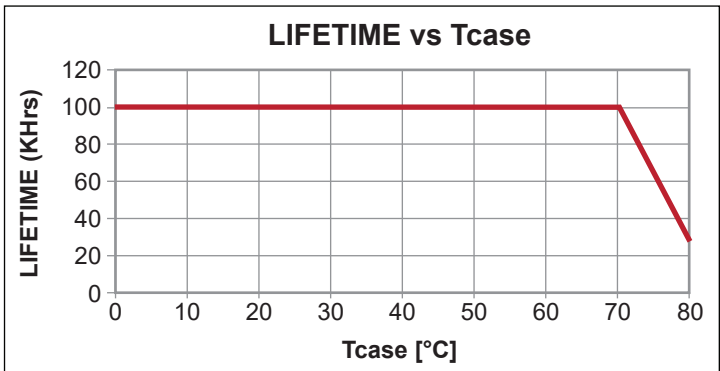
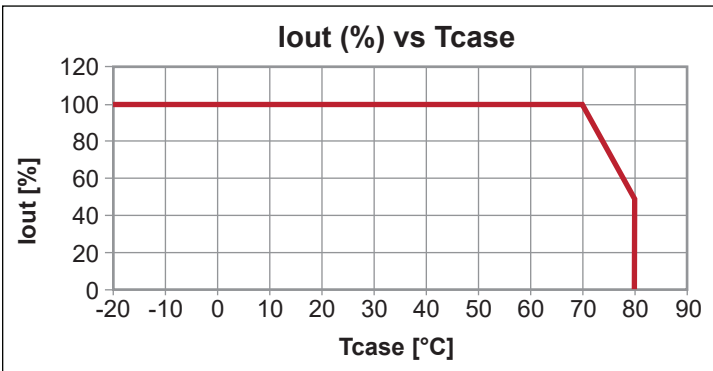

### ABOUT THE FLEXTOOL WIRELESS PROGRAMMER

The FlexTool wireless programmer is used to program Magnitude’s AFLEX Series of LED drivers. By using the FlexTool, users can quickly and smoothly configure the driver’s parameters without applying power or wires to the driver.

With the FlexTool software, you can easily save driver configuration profiles externally and use as needed. The software provides graphic and audio indication that the driver was successfully configured.

### PROGRAMMING THE AFLEX LINEAR DRIVER

#### Programmable Output Power & Current

Power is programmable in 1W steps. Current is programmable in 1mA steps.

#### Dimming Control

- Dim-to-Off: Check box (yes/no); Factory Default: Checked (yes)
- Dimming Curve: Logarithmic or Linear; Factory Default: Linear
- Dimmer Type: 0-10(V) or None; Factory Default: 0-10(V)
- Output current at Minimum Dimming level ; Factory Default : 1mA (maximum 250mA)

#### LED Thermal Protection

- Temperature Derating Start; Factory Default: 70°C
- Temperature Derating End; Factory Default: 100°C
- Min. Current before Shut-Off; Factory Default: 1mA



The screenshot shows the 'Profile Details' window in the FlexTool software. It contains several configuration sections:

- DS Feed:** Linear (selected)
- Output Power:** 60 W (it is possible to define any power)
- Output Current:** 1400 mA
- Output Current at MIN Dimmer:** 0 mA
- Dimming Control:**
  - Dim to Off:
  - Dimming Curve:  Logarithmic  Linear
  - Dimmer Type:  0-10  None
- LED Thermal Protection:**
  - Temperature Derating Start: 70 °C
  - Temperature Derating End: 100 °C
  - Min. Current before Shut Off: 1 mA

At the bottom, there is a 'Save & Close' button.

Two graphs are displayed on the right side:

- Dimming Curve:** A line graph showing Output current [mA] on the y-axis (0 to 1800) versus 0-10V Dimmer Level [V] on the x-axis (0 to 11). The curve is linear from (0,0) to (9,1400) and then remains constant at 1400 mA up to 10V.
- Temperature Graph:** A line graph showing Output current [mA] on the y-axis (0 to 1500) versus Temperature °C on the x-axis (0 to 140). The current is constant at 1400 mA until 70°C, then decreases linearly to 0 mA at 100°C.